

Programmable Synthesizer HM8134-2

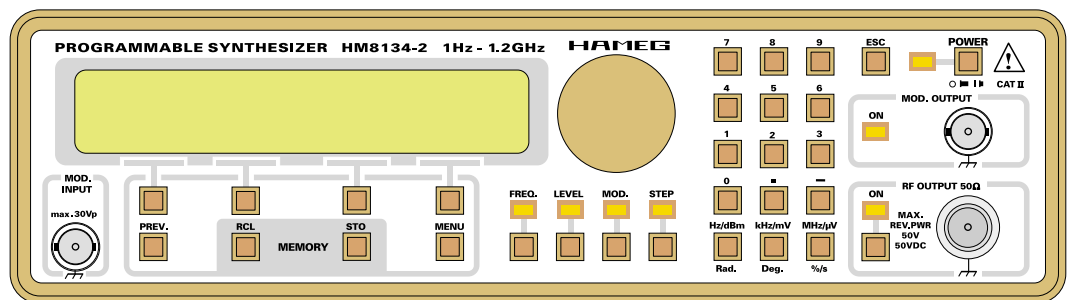

General information regarding the CE marking 2

General informations 5

- Safety 5
- Operating conditions 5
- Warranty 5
- Power requirement 5

Control elements HM8134 (Front side): 6

Control elements HM8134 (Rear side): 6

Getting started 7

- Main display 7
- «Escape» key (13) 7
- Setting parameters 7
- Selecting frequency 7
- Selecting level 7
- Selecting modulations 8
- Amplitude modulation (AM) 9
- Frequency modulation (FM) 10
- Phase modulation (PM) 11
- GATE modulation 11
- Selecting step 12

MENU key 12

- Reference «Ref» 12
- Special function «Sfc» 13
- Beeper «Beep» 13
- Encoder «Enco» 13
- Interface «Com» 13

Serial interface (standard HO90) 13

RS232 interface (option HO89) 13

IEEE-488 interface (option HO88) 13

- PREV. key 13
- ON/OFF key 13
- RCL-STO keys 13
- REMOTE OPERATION 13
- Interfaces 13

Commands supported 14

- General 14
- Description 14
- Commands description 14
- Preliminary conventions 14
- Initialisation 14
- General commands 14
- Bus commands 14
- Sound commands 14
- Commands tree - OUTPUT 14
- Commands tree - POWER 14
- Commands tree - FREQUENCY 14

RF-Synthesizer HM8134-2

- Commands tree - PHASE 15
- Commands tree - PULM (PULse Modulation) 15
- Commands tree - AM (Amplitude Modulation) 15
- Commands tree - FM (Frequency Modulation) 16
- Commands tree - PM (Phase Modulation) 16
- Commands tree - SYSTEM 17

Error codes and their meaning 18

Flow Chart Menu 19

Synoptic 26

- Referency loop CREF 26
- Principal loop PLL1-134 26
- Secondary loop PLL2-134 27
- Transposition TRA-134 27
- Frequency synthesizer DDS134 28
- Level lock loop AMPL134 28
- Programmable attenuator ATP134 29

Conversion 30



Herstellers
Manufacturer
Fabricant

HAMEG GmbH
Kelsterbacherstraße 15-19
D - 60528 Frankfurt

Bezeichnung / Product name / Designation:

Programmable 1GHz Synthesizer

Typ / Type / Type: HM8134

mit / with / avec: -

Optionen / Options / Options: HO88, HO89

mit den folgenden Bestimmungen / with applicable regulations / avec les directives suivantes

EMV Richtlinie 89/336/EWG ergänzt durch 91/263/EWG, 92/31/EWG
EMC Directive 89/336/EEC amended by 91/263/EWG, 92/31/EEC
Directive EMC 89/336/CEE amendée par 91/263/EWG, 92/31/CEE

Niederspannungsrichtlinie 73/23/EWG ergänzt durch 93/68/EWG
Low-Voltage Equipment Directive 73/23/EEC amended by 93/68/EEC
Directive des équipements basse tension 73/23/CEE amendée par 93/68/CEE

KONFORMITÄTSEKTLÄRUNG
DECLARATION OF CONFORMITY
DECLARATION DE CONFORMITE

HAMEG®
Instruments

Angewendete harmonisierte Normen / Harmonized standards applied / Normes harmonisées utilisées

Sicherheit / Safety / Sécurité

EN 61010-1: 1993 / IEC (CEI) 1010-1: 1990 A 1: 1992 / VDE 0411: 1994

Überspannungskategorie / Overvoltage category / Catégorie de surtension: II
Verschmutzungsgrad / Degree of pollution / Degré de pollution: 2

Elektromagnetische Verträglichkeit / Electromagnetic compatibility
Compatibilité électromagnétique

EN 61326-1/A1

Störaussendung / Radiation / Emission: Tabelle / table / tableau 4, Klasse /
Class / Classe B.

Störfestigkeit / Immunity / Imunitee: Tabelle / table / tableau A1.

EN 61000-3-2/A14

Oberschwingungsströme / Harmonic current emissions / Émissions de courant
harmonique:

Klasse / Class / Classe D.

EN 61000-3-3

Spannungsschwankungen u. Flicker / Voltage fluctuations and flicker /
Fluctuations de tension et du flicker.

Datum /Date /Date
15.01.2001

Unterschrift / Signature /Signature

E. Baumgartner
Technical Manager/Directeur Technique

General information regarding the CE marking

HAMEG instruments fulfill the regulations of the EMC directive. The conformity test made by HAMEG is based on the actual generic- and product standards. In cases where different limit values are applicable, HAMEG applies the severer standard. For emission the limits for residential, commercial and light industry are applied. Regarding the immunity (susceptibility) the limits for industrial environment have been used.

The measuring- and data lines of the instrument have much influence on emission and immunity and therefore on meeting the acceptance limits. For different applications the lines and/or cables used may be different. For measurement operation the following hints and conditions regarding emission and immunity should be observed:

1. Data cables

For the connection between instruments resp. their interfaces and external devices, (computer, printer etc.) sufficiently screened cables must be used. Without a special instruction in the manual for a reduced cable length, the maximum cable length of a dataline must be less than 3 meters and not be used outside buildings. If an interface has several connectors only one connector must have a connection to a cable.

Basically interconnections must have a double screening. For IEEE-bus purposes the double screened cables HZ72S and HZ72L from HAMEG are suitable.

2. Signal cables

Basically test leads for signal interconnection between test point and instrument should be as short as possible. Without instruction in the manual for a shorter length, signal lines must be less than 3 meters and not be used outside buildings.

Signal lines must be screened (coaxial cable - RG58/U). A proper ground connection is required. In combination with signal generators double screened cables (RG223/U, RG214/U) must be used.

3. Influence on measuring instruments.

Under the presence of strong high frequency electric or magnetic fields, even with careful setup of the measuring equipment an influence of such signals is unavoidable.

This will not cause damage or put the instrument out of operation. Small deviations of the measuring value (reading) exceeding the instruments specifications may result from such conditions in individual cases.

HAMEG GmbH



RF-Synthesizer HM8134-2

- Frequency range: 1Hz to 1200MHz
- Frequency accuracy $\pm 5 \times 10^{-7}$ (optional $\pm 5 \times 10^{-8}$)
- Frequency resolution 1Hz
- AM / FM / PM / GATE - Modulation
- Optional IEEE-488 and RS 232 - Interface

RF for Laboratory and Service

The **HM8134-2** is an exceptionally low-price RF-Synthesizer combining high performance with fast and easy operation. It has excellent basic specifications, including such characteristics as high frequency stability, fast frequency change response time, spectral purity, and repeatable signal output levels.

The **HM8134-2** provides continuous frequency coverage from as low as 1Hz up to 1,2GHz. This wide range covers the most commonly needed spectrum of audio, video, and IF frequencies, as well as the RF frequencies used by receivers and transmitters in a wide variety of communication systems. The frequency resolution is 1Hz.

The other propriety are a four modulation (AM/FM/PM/GATE), a modulation source internal may be varied between 10Hz and 100kHz, a modulation shape are (SIN / SQR / TRI / +RP / -RP). External input allow modulation between DC and 100kHz. The FM deviation may be varied up to ± 400 kHz and the PM deviation 10rad, the AM modulation depth is variable from 0 to 100% and the GATE on/off Ratio between 50dB and 80dB.

The **HM8134-2** have a fast response time of 10ms for frequency and amplitude changes (same range frequency

and without modulation) is another outstanding characteristic of this instrument.

The instrument parameters are all clearly displayed on two lines of 20 characters each on a backlight LCD.

The **HM8134-2** was designed with the thought of operational ease and productivity in mind. Menu-driven operation gives clear, up-front information at every stage. Parameters are either set via the center rotary dial or by the front-panel keypad. A maximum of ten frequently used instrument settings can be stored in a non-volatile memory.

Full programmability for use in automated measuring systems is provided by the optional IEEE-488 (HO88) or RS232 (HO89) interfaces. Either one of these options can be factory-installed at the time of purchase, or can easily be added by the user.

With the **HM8134-2**, HAMEG offers a price/performance ratio unsurpassed in today's market. As already successfully demonstrated in its oscilloscope and Modular System HM8000 series, HAMEG has again reached its goal of cost-effective, high-quality instrumentation by concentrating on essentials, keeping operation simple without omitting important functions.

Technical specifications HM8134-2

Specifications

(Referency temperature :23°C ±2°C)

Frequency	
Range:	1Hz to 1200MHz
Resolution:	1Hz
Setting time:	< 10ms (if same range) < 60ms (range to range)

Standard 10MHz	
Stability (10 to 40°C):	≤ ± 0,5ppm
Aging:	≤ ± 1ppm/year

Option OCXO 10MHz	
Stability (10 to 40°C):	≤ ± 5 10 ⁻⁸
Aging:	≤ ± 5 10 ⁻⁹ /day

Output referency internal:	(BNC jack in back panel)
Output voltage:	TTL
Input referency external:	(BNC jack in back panel)
Input frequency:	10MHz ±5ppm
Input level:	> 0dBm

Spectral purity	
without modulation, level ≤ +10dBm	
Harmonic:	1Hz to 1200MHz ≤ -30dBc
Non harmonic:	16MHz to 500MHz ≤ -55dBc (> 15kHz offset)
Residual-FM:	< 50Hz RMS to 1GHz (0,3-3kHz BW)
Residual-PM:	< 0,06rad RMS to 1GHz (0,3-3kHz BW)
Residual-AM:	< 0,1% (50Hz to 10kHz)

Phase noise (dBc/Hz)

Range	Offset		
	1kHz	10kHz	100kHz
<16MHz	-82	-100	-121
16 - 256MHz	-74	-84	-108
256 - 512MHz	-80	-90	-115
512 - 1024MHz	-74	-84	-108

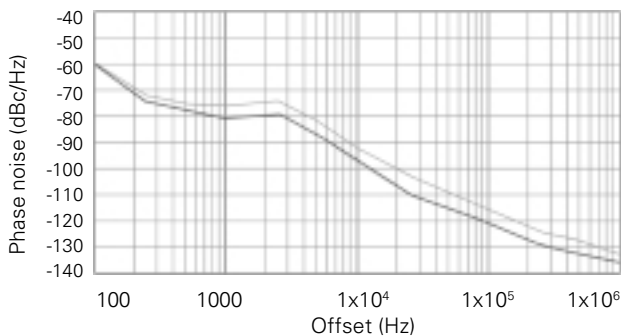

Output level	
Range:	-127dBm to +13dBm
Resolution:	0,1dB
Accuracy:	± 0,5dBm level ≥ -57dBm ±(1dBm+0,4dBm/10dB)level < -57dBm
Setting time:	< 10ms (with modulation) < 60ms (without modulation)
Impedance:	50Ω
V.S.W.R.:	< 1,5

Modulation source	
Modulation source int:	10Hz to 100kHz (40kHz in AM) Sine 10Hz to 20kHz Sqr, Tri, Rmp+, Rmp-
Resolution:	10Hz
Input modulation ext:	(BNC jack in front panel)

Input impedance:	10kΩ
Input voltage:	the modulation is calibrated with 2Vcc
Output source (int,ext):	(BNC jack in front panel)
Output voltage:	≤ ± 2V

Amplitude modulation	
Level:	≤ +7dBm
Modulation source:	internal ,external
AM-depth:	0 to 100%
Resolution:	0,1%
Accuracy (internal sine):	±4% of reading ±0,5% of value (AM-depth ≤ 80% , Fmod ≤ 1kHz) ±7% of reading ±0,5% of value (AM-depth ≤ 80% , Fmod > 1kHz)
Bandwidth ext:	(to 1dB) 10Hz-50kHz AC coupled
Distorsion:	<2% (AM-depth ≤ 60% to 1kHz) <6% (AM-depth ≤ 80% , level = +7dBm 10Hz to 20kHz)

Frequency modulation	
Modulation source:	internal ,external
Deviation:	±200Hz to ±150kHz (<16MHz) ± 2kHz to ±400kHz (16 -256MHz) ± 1kHz to ±200kHz (256 -512MHz) ± 2kHz to ±400kHz (512 -1024MHz)
Resolution:	100Hz
Accuracy (internal sine):	±2% Fmod ≤ 1kHz + residual-FM ±5% Fmod > 1kHz + residual-FM
Bandwidth ext:	(to 1dB) DC coupled: DC- 30kHz(100kHz <16MHz) NUM AC coupled: 10Hz- 30kHz(100kHz <16MHz) NUM 30kHz-100kHz ANA
Distorsion:	< 3% for deviations ≥ 10kHz

Phase modulation	
Modulation source:	internal ,external
Deviation:	0 to 3,14rad (<16MHz) 0 to 10rad (16 - 1200MHz)
Resolution:	0,01rad
Accuracy (internal sine):	±5% to 1kHz + residual-PM
Bandwidth ext:	(to 1dB) DC coupled: DC- 30kHz (100kHz <16MHz) NUM AC coupled: 10Hz- 30kHz (100kHz <16MHz) NUM 30kHz-100kHz ANA
Distorsion:	< 3% for Fmod=1kHz, Deviation=10rad

Gate modulation	
Modulation source:	external
on/off Ratio:	≥ 65dB (<16MHz) ≥ 80dB (16MHz - 512MHz) ≥ 50dB (512MHz -1200MHz)
Rise/Fall time:	≤ 1,5μs (<16MHz) ≤ 7,5μs (16MHz -1200MHz)
Delay time:	≤ 1,5μs (<16MHz) ≤ 15μs (16MHz -1200MHz)
Input modulation:	(BNC jack in back panel)
Input level:	TTL: 0 OFF 1 ON or 1 OFF 0 ON

General	
Interfaces:	options bus IEEE-488(HO88) or RS232(HO89)
IEEE-488 functions:	(T6),(L4) SH1,AH1,RL1,DC1,DT0 and R0(HO80)
Set-up memory locations:	10
Dimensions:	285 X 75 X 365 (W X H X D)
Weight:	approx. 10kg
Power consumption:	approx. 70VA
Operating conditions:	+0°C to +40°C
Humidity:	10% - 90% no condensation
Warm up time:	typ. 60min.for the specifications
Supply voltages:	115/230V ±10% , 50-60Hz
Safety:	classe I (IEC 1010-1/VDE 0411)

Safety

The instrument has been designed and tested in accordance with VDE 0411, safety requirements for electrical equipments for measurement, control and laboratory use. It has left the factory wholly conform to this standard. Thus it is also in accordance with the International standard IEC Publication 1010-1 and the European standard EN 61010-1.

The case chassis and all measuring terminals are connected to the protective earth contact of the appliance inlet. The instrument operates according to safety Class I (three-conductor power cord with protective earthing conductor and a plug with earthing contact).

CAUTION:

The mains/line plug shall only be inserted in a socket outlet provided with a protective earth contact. The protective action must not be negated by the use of an extension cord without a protective conductor (or other means).

The mains/line plug should be inserted before connections are made to measuring circuits. Whenever it is likely that protection has been impaired, the instrument shall be made inoperative and be secured against any unintended operation. The protection is likely to be impaired if, for example, the instrument

- shows visible damage.
- fails to perform the intended measurements.
- has been subjected to prolonged storage under unfavourable conditions (e.g. in the open or in moist environments).
- has been subject to severe transport stress (e.g. in poor packaging).

In case of leakage coming from a broken «lcd» display and contact with skin, clean with pure water and soap. When the metallic case is open or replaced, the instrument has to be disconnected from the power. If measurements or calibrations are necessary with an open instrument, they must be performed by a qualified technician.

Operating conditions

The instrument has been designed for indoor use. The permissible ambient temperature range during operation is +0°C to +40°C, nevertheless refer to the technical specifications at +23°C ±2°C. It may occasionally be subjected to temperatures -10°C without degrading its safety. The permissible ambient temperature range for storage or transportation is -40°C to +60°C.

The maximum operating altitude is up to 2200m. The maximum relative humidity is up to 80%.

If condensed water exists in the instrument it should be acclimatized before switching on. In some cases (e.g. extremely cold) two hours should be allowed before the instrument is put into operation. The instrument should be kept in a clean and dry room and must not be operated in explosive, corrosive, dusty, or moist environments. The instrument can operate in any position, but the convection cooling must not be impaired and the ventilation holes must not be covered.

Warranty

HAMEG warrants to its customers that the products it manufactures and sells will be free from defects in materials and workmanship for a period of 2 years.

This warranty shall not apply to any defect, failure or damage caused by improper use or inadequate maintenance and care. This warranty is limited to repair and if necessary to replace the instrument according to the decision of HAMEG only.

HAMEG shall not be obliged to provide service under this warranty to repair damage resulting from attempts by personnel other than HAMEG representatives to install, repair, service or modify these products. In order to obtain service under this warranty, customers must contact and notify the distributor who has sold the product.

Each instrument is subjected to a quality test with 24 hours burn-in before leaving the production. Practically all early failures are detected by this method. In the case of shipments by post, rail or carrier it is recommended that the original packing is carefully preserved. Transport damages and damage due to negligence are not covered by the guarantee. In the case of a complaint, a label should be attached to the housing of the instrument which describes briefly the faults observed. If at the same time the name and telephone number (dialing code and telephone or direct number or department designation) is stated for possible queries, this helps towards speeding up the processing of guarantee claims.

Power requirement

The instrument is designed for a power source of 110V/220V 50Hz. The frequency and the voltage can fluctuate to 10%. An AC power cord is supplied with the instrument. Connect it to the power receptacle on the rear panel. Before connecting the instrument to the power source, always make certain that the line voltage switches on the rear panel are set to the position corresponding to the voltage of the AC power source. The instrument is protected by a slo-blow fuse installed in the fuse holder.

Control elements HM8134

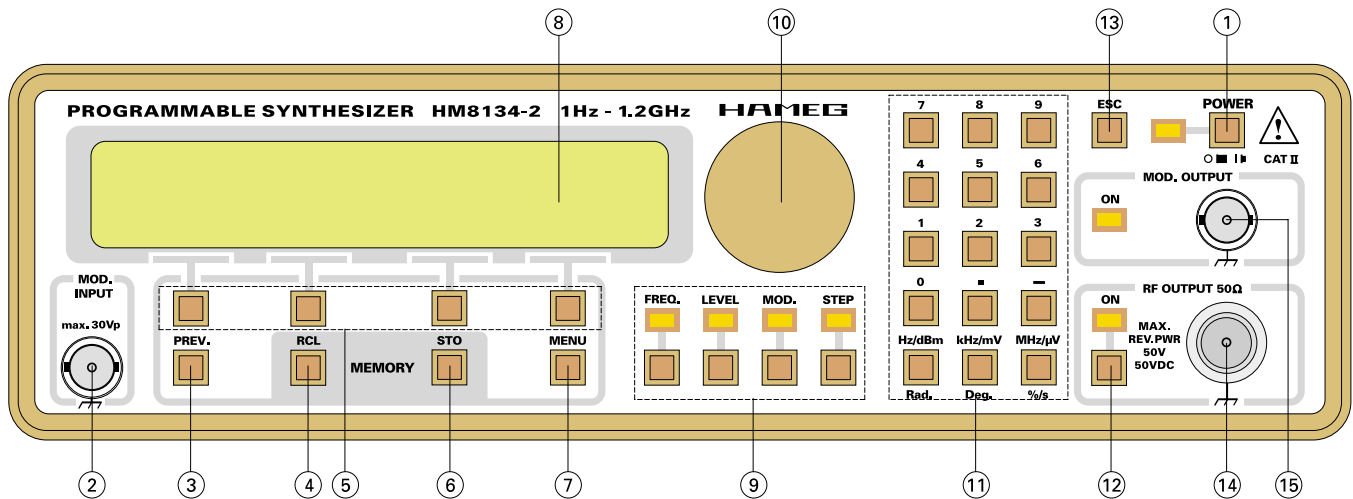

Control elements HM8134 (Front side):

- | | |
|----------------------------------------------------------------------------------------------------------------------------------------------------------------------------------------------------------------------------------------------------------------------------------------------------------------------------------------------------------------------------------------------------------------------------------------------------------------------------------------------------------------------------|-------------------------------------------------------------------------------------------------------------------------------------------------------------------------------------------------------------------------------------------------------------------------------------------------------------------------------------------------------------------------------------------------------------------------------------------------------------------------------------------------------------------------------------------------|
| <p>(1) POWER
On / Off switch and led.</p> <p>(2) MOD. IN
Input of external modulation.</p> <p>(3) PREV.
Selection of previous menu.</p> <p>(4) MEMORY RCL
Key for recalling one of 10 memories for instrument settings.</p> <p>(5) CONTEXT SENSITIVE KEYS
Action depending on the context display.</p> <p>(6) MEMORY STO
Key for storing one of 10 memories for instrument settings.</p> <p>(7) MENU
Input key in the configuration menu.</p> | <p>(8) DISPLAY
Two lines of 20 characters each on a backlight LCD.</p> <p>(9) FUNCTIONS
Functions keys and leds.</p> <p>(10) DIGITAL ROTARY CONTROL</p> <p>(11) NUMERIC KEYPAD
Input parameters with unit validation.</p> <p>(12) ON/OFF
Key for activation of output.</p> <p>(13) ESC.
Cancels the current display.</p> <p>(14) RF OUT
Signal output.</p> <p>(15) MOD. OUT
Output for modulation signal.</p> <p>(16) MAINS / LINE SOCKET</p> |
|----------------------------------------------------------------------------------------------------------------------------------------------------------------------------------------------------------------------------------------------------------------------------------------------------------------------------------------------------------------------------------------------------------------------------------------------------------------------------------------------------------------------------|-------------------------------------------------------------------------------------------------------------------------------------------------------------------------------------------------------------------------------------------------------------------------------------------------------------------------------------------------------------------------------------------------------------------------------------------------------------------------------------------------------------------------------------------------|

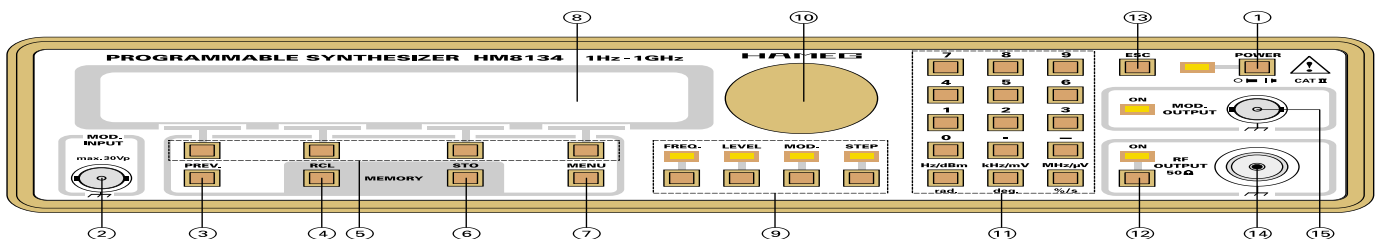

Control elements HM8134 (Rear side):

- | | |
|--------------------------------------------------------------------------------------------------------------|-----------------------------------------------------------------------------------------------------------------------------------------------------|
| <p>(17) VOLTAGE SELECTOR</p> <p>(18) FUSE</p> <p>(19) GATE INPUT
TTL-compatible</p> | <p>(20) REF. 10MHz OUTPUT</p> <p>(21) REF. 10MHz INPUT</p> <p>(22) INTERFACE
Connector interface HO90 (Option HO88/89)</p> |
|--------------------------------------------------------------------------------------------------------------|-----------------------------------------------------------------------------------------------------------------------------------------------------|

Getting started

After depressing the power (red) key (1), the HM8134 display will successively contain the following messages:

- the type (SYNTHESIZER) and the reference of the instrument (HM8134)
- the self-test messages «RAM checking» and «DDS loading»
- the reference frequency in progress (internal or external)
- the type of interface (HO88 / HO89 / HO90)
- IEEE488 address if the option is present.

The unit takes again the previous configuration existing before switching off . The output signal is always off. Factory configuration

At delivery the instrument is adjusted for a basic set-up as follows:

- Frequency: 1000MHz
- Level: +7dBm
- No modulation
- Internal reference frequency
- Fmod: 1kHz, Shape: sine (for all modulations)
- Dev: 20kHz (FM), Dev: 1rad (PM) , Depth: 50% (AM)
- Backlight medium, contrast maximum.
- Sound indicator: none.
- Rotary control: on.
- If HO90 default config (4800 bauds / 1 stop / 8 bits)

This basic adjustment can be recalled at any time as follows:

- Switch off the unit.
- Switch on the unit and hold the «ESC» key until hearing several «beeps».

This procedure is specially useful in case of doubt.

Caution:
The 10 memories storing configurations are erased and replaced by the previous basic adjustments.

Main display

This display shows the frequency and level of the RF output signal and the reference in use (INT or EXT) too. We get, if no modulation (AM, FM, PM) is turned on:

1200.000000MHz NoMod
 +13.0dBm REFint

Moreover, it contains some modulation parameters (for example in case of AM modulation , shape SQR and Fmod = 1kHz)

1200.000000MHz AMsqR
 +7.0dBm 1.0kHz

We leave this state by pressing one of the function (9) or one of the four context sensitive keys (5).

«Escape» key (13)

The «ESC» key allows the user to be back in the main display, unselecting the current function (9) or cancelling the numeric keypad input.

Setting parameters

Frq: 120.000000 MHz
 - stp + ◀ cur ▶

Once a parameter is selected (for exemple «FREQ.») with a function key (9) , a new value of this parameter can be entered from the data keypad (11) or modified by the digital rotary (10) or by one of the four context sensitive keys below the displayed marks - and + (for applying step) (5).

Operation of the data keypad is conventional. Depress successively the numeric keys representing the parameter value and at the end depress the unit key (for example MHz or dBm ...). Note that it is not necessary to enter any trailing zeroes.

Before the unit selection , it is possible to cancel the value by pressing the «ESC» key (13) , the previous value is restored. The choice of the units is free but the instrument will display the properest unit (for example 1 to 3 digits on the left of the decimal point) .

The encoder modifies the value of the digit underlined by the cursor (even if the cursor underlines a blank position which is considered as 0). The cursor move to another position by pressing the keys (5) below < and > and the value can be increased or decreased by - and +.

An improper value is announced by a warning message (except for the out of range encoder and steps) and the sound indicator.

Selecting frequency

After pressing the «FREQ» function key (9),we get:

Frq: 120.000000 MHz
 - stp + ◀ cur ▶

A new value of this carrier can be entered from the data keypad (11) or modified by the digital rotary (10) or one of the four context sensitive keys (5). For more details, refer to the paragraph « setting parameters».

The frequency range is: 1Hz to 1024MHz.

The resolution is 1Hz, if a value is entered with a higher resolution the instrument makes a truncation keeping 1Hz resolution.

Selecting level

After pressing the «LEVEL» function key (9), we get:

Level: -127.0 dBm
 - stp + ◀ cur ▶

Operation - Setting parameters

A new value of this level can be entered from the data keypad (11) or modified by the digital rotary (10) or one of the four context sensitive keys (5). For more details, refer to the paragraph « setting parameters».

The level range is:

- -127dBm to +13dBm without amplitude modulation.
- -127dBm to +7dBm with amplitude modulation.
- The resolution is 0.1dBm

The level displayed is specified for a loading impedance of 50. The choice of the unit is made by the keys (11)» dBm/mV/μV «. For the volt unit the instrument performs a three digits conversion according to the properest range (nV/μV/nV).

Caution:

When the AM modulation is on, the instrument automatically set the limit to +7dBm, for avoiding to exceed the dynamic of the output amplifier.

Selecting modulations

After pressing the «MOD.» (9) function key, we get:

```
* MODULATION MENU *
  AM   FM   PM   GATE
```

Now the modulation type is selected by pressing one of the four context sensitive keys (5) corresponding to:

- AM modulation.
- FM modulation.
- PM modulation.
- GATE modulation.

The return to the previous display is possible by pressing the «PREV.» key (3).

After selecting the type of modulation, the display is (FM MENU):

```
***** FM MENU *****
Shape Fmod Dev ▶Off
```

Again, the selection of the parameters for AM/FM/PM is made by pressing one of the four context sensitive keys (5) corresponding to:

- Shape of internal modulation signal.
- Frequency of the internal modulation signal.
- The deviation (or depth in AM).
- The modulation state.

The return to the previous display is possible by pressing the «PREV.» key (3).

After selecting «Shape» option, we get in that case (AM SHAPE MENU).

The shape of the internal modulation signal may be modified by the context sensitive keys (5). The active signal is pointed out by the sign.

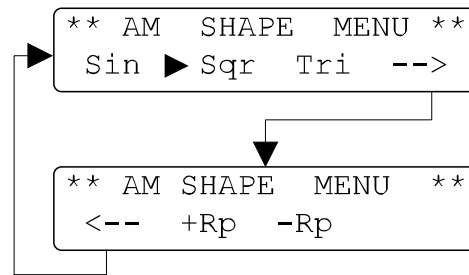

The return to the previous menu is possible by pressing the «PREV.» key (3).

After selecting «Fmod» option, we get (from AM MENU)

```
AM Fmod: 1.000 kHz
- stp + ◀ cur ▶
```

The frequency of internal modulation signal may be directly change by numeric keypad (11) or modified by the digital rotary (10) or one of the four context sensitive keys (5). The return to the previous menu is possible by pressing the «PREV.» key (3).

The frequency range is:

- 10Hz to 100kHz Sine by step 10Hz (40kHz in AM).
- 10Hz to 20kHz Tri,Sqr,+Rp,-Rp by step 10Hz (Sqr in FM and PM).

The modulation is turned on by pressing the context sensitive key below the string «off»; one time for turning the internal source on and a second time for turning the external source on. The active source is pointed out by the triangle beside the option. The annunciator of the MOD.OUT. is lighting.

```
***** FM MENU *****
Shape Fmod Dev ▶Int
```

More generally, the modulation is turned off by pressing the key corresponding to the active source one or two time depending on witch one is in progress (OffIntExtOff). The return to the previous menu is possible by pressing the «PREV.» key (3). In external AM, the only one possible option is to change the depth (see corresponding paragraph).

The frequency of the external modulation must be in a range:

- 10Hz to 50kHz in AM.

In external FM or PM several cases are possible depending on the carrier frequency.

For carrier frequencies < 16MHz, we get (for FM):

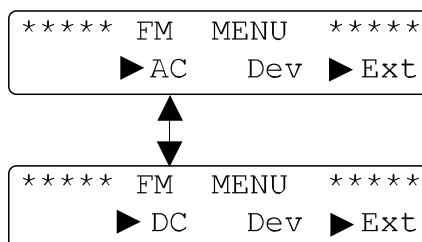

- DC coupled NUM (DC-100kHz).
- AC coupled NUM (10Hz-100kHz).
- Deviation (see corresponding paragraph).

example 1:

```
1.000kHz FMext
+ 0.0dBm
```

CH1 → modulation: first pulse width 150s.
second pulse width 1.1ms.
period 2.5ms (Fmod: 400Hz).

CH2 → modulated signal (deviation: 2kHz).



for carrier frequencies 16MHz, we get (for FM):

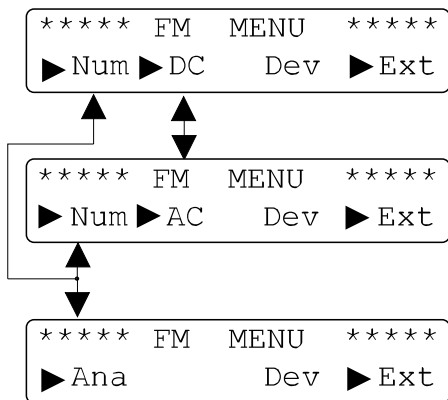

- DC coupled NUM (DC-30kHz).
- AC coupled NUM (10Hz-30kHz).
- AC coupled ANA (30kHz-100kHz)
- Deviation (see corresponding paragraph).

example 2:

```
400.000000MHz FMext
+ 0.0dBm
```

In this example, external modulation signal is a «trinary» code composed of 9 bits; 1 bit being composed itself of 2 narrow or/and wide pulses, depending on the combinaison expected:

- A bit composed of 1 wide and 1 narrow pulses is a bit «OPEN».
- A bit composed of 2 narrow pulses is a bit «LOW».
- A bit composed of 2 wide pulses is a bit «HIGH».

For detecting the first bit, a synchronisation bit (long low level) is present. The modulation frequency is here of 20Hz.

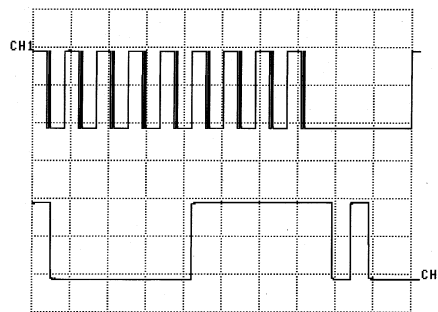

CH1 → modulation: narrow pulse of 200µs.
wide pulse of 1.8ms.
synchronisation bit of 14ms.

CH2 → zoom of CH1.

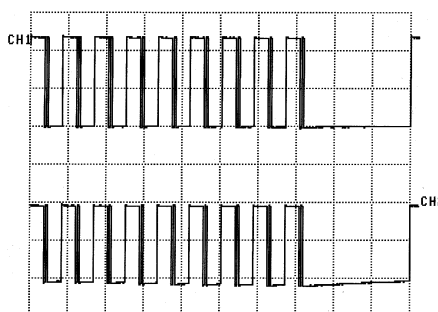

CH1 → demodulated signal: DC coupled, NUM position.
CH2 → demodulated signal: AC coupled, NUM position.

The return to the modulation menu is possible by pressing the «PREV» key (3) and the return to the main display by pressing the «ESC» key (13).

External modulation input is on the front panel «MOD.IN» (2). The signal can be of any shape or amplitude, however the AM-depth or FM/PM deviation programmed is calibrated only for a 2 Vcc signal at the input.

Amplitude modulation (AM)

From the AM menu, after selecting of the context sensitive keys «D%» (5), we get:

```
AM Depth: 100.0 %
- stp + ◀ cur ▶
```

A new value of this depth can be entered from the data keypad (11) or modified by the digital rotary (10) or one of the four context sensitive keys (5).

The depth range may be change from: 0 to 100% with a resolution of 0.1%.

The return to the previous menu is possible by pressing the «PREV» key (3) and the return to the main display by pressing the «ESC» key (13).

example 3:

For AM sine (depth : 50%), we get:

```
300.000kHz AMsin
+ 7.0dBm 10.0kHz
```

Operation - Frequency Modulation

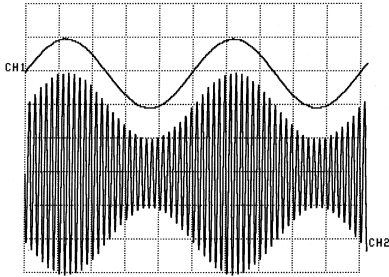

example 4:

For AM square (depth: 50%), we get:

```
300.000kHz  AMsqr
+ 7.0dBm   10.0kHz
```

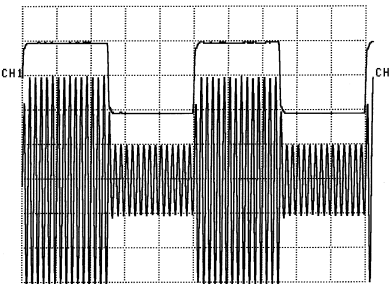

example 5:

For AM triangle (depth: 50%), we get:

```
300.000kHz  AMtri
+ 7.0dBm   10.0kHz
```

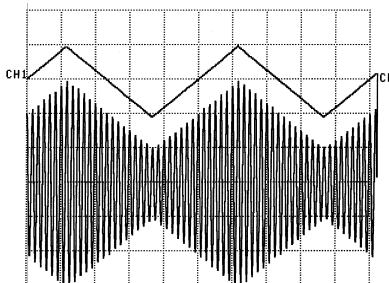

example 6:

For AM positive ramp (depth: 50%), we get:

```
300.000kHz  AM+rp
+ 7.0dBm   10.0kHz
```

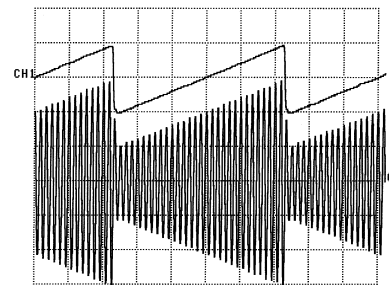

example 7:

For AM negative ramp (depth: 50%), we get:

```
300.000kHz  AM-rp
+ 7.0dBm   10.0kHz
```

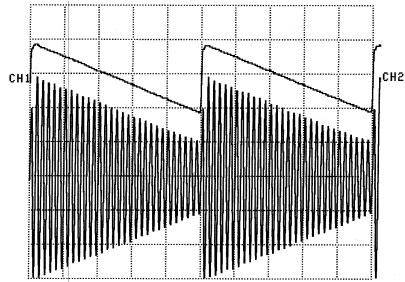

Frequency modulation (FM)

From the FM menu, after selecting of the context sensitive key «Dev» (5), we get:

```
1200.000000MHz  FMsin
+ 0.0dBm        1.0kHz
```

A new value of this deviation can be entered from the data keypad (11) or modified by the digital rotary (10) or one of the four context sensitive keys (5).

The deviation range may be change by step of 100Hz from:

- ± 200Hz to ± 150kHz (< 16MHz).
- ± 2kHz to ± 400kHz (16 - 256MHz).
- ± 1kHz to ± 200kHz (256 - 512MHz).
- ± 2kHz to ± 400kHz (512 - 1024MHz).

The return to the previous menu is possible by pressing the «PREV» key (3) and the return to the main display by pressing the «ESC» key (13).

example 8:

For FM sine, we get:

```
1200.000000MHz  FMsin
+ 0.0dBm        1.0kHz
```

(deviation: 400kHz)

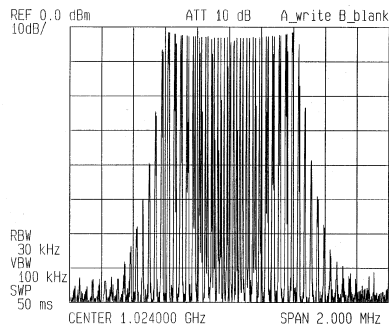

example 9:

For FM square, we get:

100.000kHz FMsqr
+10.0dBm 6.0kHz

CH1 → modulation.
CH2 → modulated signal (deviation: 80kHz).

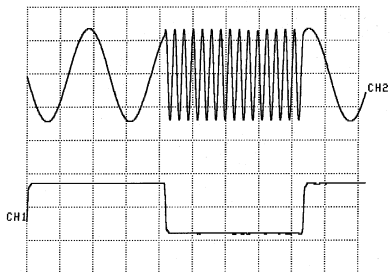

It is a way to get a **FSK modulation**.

Phase modulation (PM)

From the PM menu, after selecting of the context sensitive key «Dev» (5), we get:

PM DEV: 10.00 rad
- stp + ◀ cur ▶

A new value of this deviation can be entered from the data keypad (11) or modified by the digital rotary (10) or one of the four context sensitive keys (5).

The deviation range may be set from:

- 0 to 3.14 rad (<16MHz).
- 0 to 10 rad (16-1024MHz),

(by step of 0.01 rad.)

The return to the previous menu is possible by pressing the «PREV» key (3) and the return to the main display by pressing the «ESC» key (13).

example 10:

For PM sine, we get: (deviation: 1rad)

1200.000000MHz PMsin
+ 0.0dBm 20.0kHz

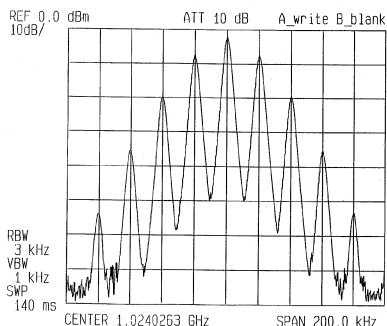

example 11:

For PM square, we get:

50.000kHz PMsqr
+10.0dBm 6.0kHz

CH1 → modulation.
CH2 → modulated signal (deviation: 1rad).



It is a way to get a **PSK modulation**.

GATE modulation

The GATE modulation is made by sampling the output carrier with logic signal (GATE) and is characterised by:

- on / off Ratio.
- Rise / Fall time.
- Delay time.

The GATE signal (level TTL) is applied at the input «GATE INPUT» in the rear panel. When the GATE signal is at the state «active» (level «1» or «0» depending on the choice), the carrier is present at the output.

After selecting the GATE option in the modulation menu, we get:

*** GATE MENU ***
▶ [square wave] [inverted square wave] ▶ On Off

Press one of the four sensitive keys (5) for selecting the active level and for turning the gate on or off. Two triangles point out the options «[square wave]», «[inverted square wave]», «on», «off». The return to the previous menu is possible by pressing the «PREV» key (3) and the return to the main display by pressing the «ESC» key (13).

100.000kHz
+ 7.0dBm [square wave] REFint

The GATE modulation can be active with an other modulation (for example the GATE modulation with AMsin modulation and Fmod = 10kHz)

example 12:

100.000kHz AMsin
+ 7.0dBm [square wave] 2.0kHz

(Fgate: 250Hz Sqr)
CH1 → AM signal (depth: 50%) and GATE modulation.
CH2 → signal with GATE modulation.

```
100.000kHz NoMod
+7.0dBm  REfint
```

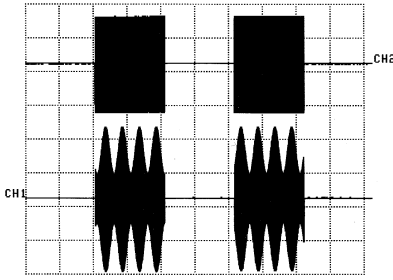

Selecting step

After pressing the «STEP» function key (9), we get:

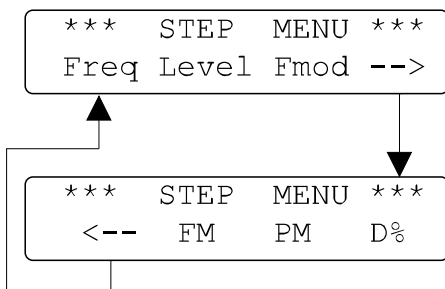

Now the step type is selected by pressing one of the four context sensitive keys (5). If the parameter is already selected, the «STEP» function key (9) allows you to directly modify the step type. Press again the step key to be back in previous display. For quantity having two possible units (level and phase), the step unit is the current unit selected for the parameter.

```
FM STEP: 10.000 kHz
- val +  cur ▶
```

A new value of this step can be entered from the data keypad (11) or modified by the digital rotary control (10) or one of the four context sensitive keys (5).

The step can be:

- frequency (FSTEP:).
- level (Level STEP:).
- modulation frequency (Fmod STEP:).
- AM-depth (AM STEP:).
- FM-deviation (FM STEP:).
- PM-deviation (PM STEP:).

MENU key

The «MENU» key (7) allow to display the configuration menu.

```
*** CONFIG MENU ***
Ref Sfc
```

The options are selected by pressing one of the two context sensitive keys (5). The return to the main display is possible by pressing the «ESC» key (13).

Reference «Ref»

```
** FREQUENCY REF **
Int ▶ Ext Locked
```

The HM8134 is basically equipped with a temperature compensated crystal oscillator 10MHz. The option (OCXO) with a high-stability 5 10-8 (10 to 40°C) is available.

At every access to the config menu and after selecting a context sensitive keys «Ref» (5). The phaselock loop of the reference is tested (Locked, Unlocked). Increased stability for the HM8134 may also be obtained from an external oscillator. The external reference frequency must be connected to the «REF.10MHz INPUT» and the internal reference frequency is available on the «REF.10MHz OUPUT» of the rear panel.

Caution:

If the reference frequency from an external source is not within specifications an «error» message will be displayed. The HM8134 is then automatically switched on the internal reference frequency.

Special function «Sfc»

After selecting the «Sfc» option in the config menu, we get:

```
* SPECIAL FUNCTION *
Beep Enco Com Lcd
```

The special function are selected by pressing the context sensitive keys (5).

Beeper «Beep»

The built-in beeper will react to every key stroke and will indicate any operation errors. The activation and adjustment of the volume is done in beeper menu, we get:

```
** BEEPER SETUP **
▶ Soft Loud None
```

- a sound (Soft).
- a sound (Loud).
- no sound (None).

Encoder «Enco»

```
** ENCODER SETUP **
▶ On Off
```

The activation of the rotary control is done in this menu by selecting the «On» or «Off» with context sensitive keys (5).

caution:

Think to check this option in case of no operating of the rotary.

Interface «Com»

The HM 8134 is basically equipped of the serial interface (HO90). The instrument is prepared for the installation of the optional IEEE-488 (HO88) or RS232 (HO89) interface. All the interfaces are galvanically isolate. Only the parameters of the installed interface appear and can be modified.

Serial interface (standard HO90)

```
** SERIAL (HO90) **
4800 NONE 8 1
```

It is possible to select the transmission rates 300, 600, 1200, 2400, 4800 or 9600 Bauds by pressing the context sensitive key (5). The other parameters are fixed:

- parity none
- 8 data Bits
- 1 stop Bit

RS232 interface (option HO89)

```
** RS232 (HO89) **
9600 NONE 8 2
```

The interface RS232 (HO 89) have the same possibility to select transmission rates. It is also possible to change the parity (even/odd/none), the width word (7 or 8 Bits) and the number of stop bits (1 or 2).

IEEE-488 interface (option HO88)

```
** IEEE488 (HO88) **
- + Addr=07
```

With this menu, it is possible to modify the instrument address on the IEEE-488 bus when the option HO88 is installed. The address can be increased or decreased in authorized limits (1 to 30) by selecting one of the two context sensitive keys (5).

Display «Lcd»

```
** LCD PARAMETERS **
-Contrast+ -Light+
```

The adjustment of the contrast and display light are selected by pressing one of four context sensitive keys (5), corresponding to « + » or « - ».

PREV. key

The previous menus is got by pressing the «PREV.» key (3).

ON/OFF key

The output «RF OUT» (14) is active only if the «ON/OFF» key (12) is pressed and the «ON» led is lighted. When the signal is not active, the output is an open circuit.

RCL-STO keys

The instrument is equipped with an internal non-volatile memory which stores all operational parameters in use (frequency, level, modulation ...) when the power is switched off. In addition to this « current set-up» storage the instrument offers the possibility to store 10 complete configurations, corresponding to current state at different time.

After pressing the «STO» key (6), we get:

```
** RECALL MEMORY **
Number : ?
```

The current configuration can be stored by pressing a numeric key from 0 to 9.

After pressing the «RCL» key (4), we get:

```
** RECALL MEMORY **
Number : ?
```

A configuration can be recalled by pressing a numeric key from 0 to 9. That becomes the current configuration.

REMOTE OPERATION

Interfaces

The HM8134 may be equipped with one of the three following interfaces:

- serial interface (HO90) which is the default equipment.
- RS232 interface (HO89) which is a special option.
- IEEE-488 interface (HO88) which is a special option.

The serial interface is a 9-pin connector (DB-9, male connector) on the rear panel.

Only three wire lines are connected inside:

- pin 2 as Txd (transmit data).
- pin 3 as Rxd (Receive data).
- pin 7 as Gnd (Ground).

Electric voltage on Rxd must be according to the RS232 hardware standard (+12/-12V max). This provides the capability to communicate with any PC computer on COM1 or COM2 port. The communication protocol is an Xon/Xoff procedure and operates as follows. Once the instrument has received a commands line (refer to the definition below), it sends the Xoff character (19 dec).

After all commands (in the received line) have been computed and executed, it sends the Xon character (17 dec), making the transmission of a new line possible. Commands are the same for all interfaces (For more details about the options refer to the corresponding manual).

When a remote command is received, the instrument displays on the second line the following message:

```
1000.000000MHz NoMod
▶ REMOTE LOCAL
```

The user may come back in Local mode by pressing the context sensitive keys (5) just below the Local option (all other keys are locked).

The user may lock all keys, by the command LK1 and in this case the display becomes:

```
1000.000000MHz NoMod
REMOTE:LOCAL LOCKOUT
```

Operation - Commands description

Commands supported

General

There are two kinds of commands. The first one is the set of old commands which are HM8133-2 compatible. They are normally understood by the instrument without changing existing programs. The second one is a new set with a similar syntax to the SCPI standard. We recommend to use these commands which are the only one described hereafter.

Description

Commands are sent by lines to the instrument, one line being a set of characters in ASCII code between 20 and 127 (dec), and terminated by an end of line terminator (10 dec) or 13 following by 10 (dec). Each line is composed of one or several simple commands (elementary) separated one another by the «;» (comma) separator.

Example: `:POWER 7 ; :FREQ 500E+6 ; :OUTP ON`

The level is at +7dBm, the frequency at 500MHz and the output signal ON. The strings of data are not case sensitive. That means lower case and upper case are the same. A simple command gives an access to a quantity or a function of the instrument. All commands acting on the same quantity are brought together syntactically in a tree structure. We are going to detail function by function beginning with the simplest and the usefulest.

Commands description

Preliminary conventions

In the lines below, we use the following conventions:

- lower cases in keywords are optional, meaning for example that the keyword «OUTPut» may be employed as OUPt (short writing) or OUTPUT (long writing).
- [] means that the keyword in brackets is optional.
- | means «exclusive or» between several parameters.
- a NR1 number is a string of digits without decimal point (1234).
- a NR2 number is a string of digits with a decimal point (1234.56).
- a NR3 number is a string representing a decimal number with an exposant (1234.56E+3).

Initialisation

*RST idem key «ESC» at power on time except beep, display, com and memory config (0-9) which are not modified

General commands

*IDN? identification
*SAV x store current state (x from 0 to 9)
*RCL x recall configuration (x from 0 to 9)
SNR? serial number
FAB? manufacture date

Bus commands

LK0 local mode enable
LK1 local mode disable
RM0 local mode
RM1 remote mode

Sound commands

BPO Beep off
BPS soft Beep
BPL loud Beep

Commands tree - OUTPUT

It brings together commands for switching the RF output signal.

Syntax:

:OUTPut[:STATe] 0 | OFF | 1 | ON (1)
:OUTPut[STATe]? (2)

The line (1) allows you to change the state, the parameters «0» or «OFF» are equivalent and turn the output off, «1» or «ON» turn the output on. The line (2) asks the output state to the instrument. It always sends back «1» for output ON and «0» for output OFF.

Examples:

:OUTP ON Ouput ON.
:OUTP 1 Same as above.
:OUTPUT ON Same as above.
:OUTPUT:STATE 1 Same as above.
:OUTP? Asks the ouput state.
:OUTPUT:STATE? Same as above.

Commands tree - POWER

It summarizes the commands for changing the level of the RF output signal.

Syntax:

:POWer[:LEVe] <NUM> (1)
:POWer[:LEVe]? (2)
:POWer:UNIT V | DBM (3)
:POWer:UNIT? (4)

The line (1) allows you to modify the level, the <NUM> parameter is a NR2 number in the range covered by the instrument. None unit must follow the number, the current unit is assumed. The line (3) allows you to change the current unit. Two parameters are possible : V for Volt (mV/uV included), or DBM for dBm.

The line (4) asks the current unit to the instrument. It sends back the same strings as the corresponding command parameters above. The line (2) asks the current level to the instrument. It sends back a NR2 number corresponding to the resolution without the unit.

Examples:

:POW:UNIT DBM Set the level unit dBm
:POWER:UNIT DBM Idem
:POW 5.7 Set the level ... 5.7 dBm
:POW:LEV 5.7 Idem ...
:POWER:UNIT? Ask the unit

Commands tree - FREQUENCY

It summarizes the commands about the signal (carrier) frequency.

Syntax:

```
:FREQuency[:CWl:FIXed] <NUM> (1)
:FREQuency[:CWl:FIXed]? (2)
```

The line (1) allows you to modify the carrier frequency, the <NUM> parameter is a NR1 or NR2 or NR3 number in the range covered by the instrument. None unit must follow the number, the Hz unit is the default one. The value is garbled (same as the keypad) to the resolution. The «CW» and «FIXed» options have no particular effect on the instrument, they are present for compatibility with programs existing in the SCPI standard. The line (2) asks the current (carrier) frequency to the instrument. It sends back a string representing a NR3 decimal number.

Examples:

```
:FREQ 678E+6 Set the frequency 678MHz
:FREQUENCY 34000000 Set the frequency 34MHz
:FREQ? Ask the frequency
:FREQ:FIX 900E+6 Set the frequency 900MHz
```

Commands tree - PHASE

It summarizes the commands for selecting the source of the reference signal.

Syntax:

```
:PHASe:SOURce INTern | EXTern (1)
:PHASe:SOURce? (2)
```

The line (1) allows you to switch the reference. Only one of the 2 parameters must be present: «INTern» for turning the internal reference on, or «EXTern» for turning the external reference on.

The line (2) asks which source is currently on to the instrument. It sends back the strings «INT» or «EXT» corresponding to the 2 options described above.

Note:

It is strongly advised to check the state you have got after a command (1) (for example simply with the query command (2)).

Examples:

```
:PHAS:SOURCE EXT Turn external ref
:PHAS:SOUR? Query
:PHAS:SOUR? Idem above but shorter
```

Commands tree - PULM (PULse Modulation)

It summarizes the commands of the GATE modulation.

Syntax:

```
:PULM:STATe 1 | ON | 0 | OFF (1)
:PULM:STATe? (2)
```

The line (1) allows you to turn on or off the GATE modulation. The «1» or «ON» parameters turn the modulation on and «0» or «OFF» turn the modulation off (if present). The line (2) allows you to pick up the state of the GATE modulation. The instrument sends back «0» (char zero) if no modulation, «1» (char one) in case of modulation.

```
:PULM:POLarity NORMal | INVert (3)
:PULM:POLarity? (4)
```

The line (3) allows you to set the validation level of the GATE modulation, the NORMal parameter is for a high level validation, and INVert is for a low level validation.

The line (4) asks the enabling level state. The instrument sends back «1» for high level (NORMal), «0» for low level (INVert).

Commands tree - AM (Amplitude Modulation)

It summarizes the commands of the AM.

Syntax:

```
:AM[:DEPT] <NUM> (1)
:AM[:DEPT]? (2)
```

The line (1) allows you to modify the depth of modulation. The <NUM> parameter is a NR2 number in the range covered by the instrument. None unit must follow the number, % unit is the default one. If the value has an accuracy higher than the resolution (0.1%), the number is rounded to the corresponding digit. The line (2) asks the current depth of modulation to the instrument. It sends back a NR2 number corresponding to the resolution (one digit after the decimal point) without the unit.

```
:AM:SOURce INTern | EXTern (3)
:AM:SOURce? (4)
```

The line (3) allows you to set the modulation source and at the same time turns the FM on.

The parameters are clear enough. The line (4) asks the source modulation to the instrument. It sends back the strings INT or EXT (not INTERN or EXTERN). If the AM is turned off, the string INT is sent back because this source is the default setting for the «AM:STAT 1» command (the operation is the same as the keypad).

```
:AM:INTern:FREQuency <NUM> (5)
:AM:INTern:FREQuency? (6)
```

The line (5) allows you to change the frequency of the internal modulation signal. The <NUM> parameter is a NR1 or NR2 or NR3 number in the range covered by the instrument. None unit must follow the number, Hz unit is the default one. The value is garbled (same as the keypad) to the resolution. The line (6) asks the current modulation frequency to the instrument. It sends back a string representing a NR3 decimal number.

```
:AM:INTern:SHAPe SIN | SQU | TRI | +RP | -RP (7)
:AM:INTern:SHAPe? (8)
```

The line (7) allows you to change the shape of the internal modulation signal. The parameters are: SIN for a sine signal, SQU for square, TRI for triangle, +RP for a positive ramp, and -RP for a negative ramp.

The line (8) asks the current shape to the instrument. It sends back the same strings as the corresponding command parameters above.

```
:AM:STATe 0 | OFF | 1 | ON (9)
:AM:STATe? (10)
```

Operation - Commands tree

The line (9) allows you to turn the AM modulation on or off. The parameters «1» or «ON» turn the AM on, and «0» or «OFF» turn the modulation off (if present).

The line (10) asks the current AM state to the instrument. It sends back «0» (char zero) if no AM is in progress, «1» (char one) if AM is present.

Example:

```
:AM:INT:FREQ 3000; SHAP SQU; DEPT 60; STAT 1
```

Commands tree - FM (Frequency Modulation)

It brings together the commands of the FM.

Syntax:

```
:FM[:DEVIation] <NUM>           (1)  
:FM[:DEVIation]?                 (2)
```

The line (1) allows you to modify the FM deviation. The <NUM> parameter is a NR1 or NR2 or NR3 number in the range covered by the instrument. None unit must follow the number, Hz unit is the default one. The value is garbled (same as the keypad) to the resolution. The line (2) asks the current FM deviation to the instrument. It sends back a string representing a NR3 decimal number.

```
:FM:SOURce INTern | EXTern       (3)  
:FM:SOURce?                       (4)
```

The line (3) allows you to set the modulation source and at the same time turns the FM on. The line (4) asks the FM source to the instrument. It sends back the strings INT or EXT (not INTERN or EXTERN).

If the FM is turned off, the string INT is sent back because this source is the default setting for the «FM:STAT 1» command (the operation is the same as the keypad).

```
:FM:INTern:FREQuency <NUM>      (5)  
:FM:INTern:FREQuency?           (6)
```

The line (5) allows you to change the frequency of the internal modulation signal. The <NUM> parameter is a NR1 or NR2 or NR3 number in the range covered by the instrument. None unit must follow the number, Hz unit is the default one. The value is garbled (same as the keypad) to the resolution.

The line (6) asks the current modulation frequency to the instrument. It sends back a string representing a NR3 decimal number.

```
:FM:INTern:SHAPE SIN | SQU       (7)  
:FM:INTern:SHAPE?                (8)
```

The line (7) allows you to change the shape of the internal modulation signal. The parameters are : SIN for a sine signal, SQU for square. The line (8) asks the current shape to the instrument. It sends back the same strings as the corresponding command parameters above.

```
:FM:STATe 0 | OFF | 1 | ON       (9)  
:FM:STATe?                        (10)
```

The line (9) allows you to turn the FM on or off. The parameters «1» or «ON» turn it on, and «0» or «OFF» turn the modulation

off (if present). The line (10) asks the current FM state to the instrument. It sends back «0» (char zero) if no FM is in progress, «1» (char one) if FM is present.

```
:FM:MODE ANA | NUM               (11)  
:FM:MODE?                         (12)
```

The line (11) allows you to switch the operating mode (depending on the input bandwidth expected) of the external modulation. The parameters ANA and NUM are the same as the options in the external FM menu (refer to the corresponding paragraph).

The line (12) asks the current mode to the instrument. It sends back the same strings as the corresponding command parameters above.

```
:FM:EXTern:COUPling AC | DC      (13)  
:FM:EXTern:COUPling?            (14)
```

The line (13) allows you to switch the external input modulation in AC or DC mode. The line (14) asks the current state to the instrument. It sends back the same strings as the corresponding command parameters above.

Example:

```
FM:INT:FREQ 9E+3; SHAP SIN; DEV 150E+3;  
MODE NUM; STAT ON
```

Commands tree - PM (Phase Modulation)

It brings together the commands of the PM.

Syntax:

```
:PM[:DEVIation] <NUM>           (1)  
:PM[:DEVIation]?                 (2)
```

The line (1) allows you to modify the PM deviation. The <NUM> parameter is a NR2 number in the range covered by the instrument. None unit must follow the number, the current unit is the default one. If the value has an accuracy higher than the resolution, the number is rounded to the corresponding digit.

The line (2) asks the current PM deviation to the instrument. It sends back a string representing a NR2 decimal number (without the unit).

```
:PM:UNIT RAD | DEG               (3)  
:PM:UNIT?                         (4)
```

The line (3) allows you to change the current unit. Two parameters are possible : RAD for radian or DEG for degree. The line (4) asks the current unit to the instrument. It sends back the same strings as the corresponding command parameters above.

```
:PM:SOURce INTern | EXTern       (5)  
:PM:SOURce?                       (6)
```

The line (5) allows you to set the modulation source and at the same time turns the PM on. The line (6) asks the PM source to the instrument. It sends back the strings INT or EXT (not INTERN or EXTERN). If the PM is turned off, the string INT is sent back because this source is the default setting for the

«PM:STAT 1» command (the operation is the same as the keypad).

```
:PM:INTern:FREQuency <NUM>      (7)
:PM:INTern:FREQuency?            (8)
```

The line (7) allows you to change the frequency of the internal modulation signal. The <NUM> parameter is a NR1 or NR2 or NR3 number in the range covered by the instrument. None unit must follow the number, Hz unit is the default one. The value is garbled (same as the keypad) to the resolution. The line (8) asks the current modulation frequency to the instrument. It sends back a string representing a NR3 decimal number.

```
:PM:INTern:SHAPE SIN | SQU        (9)
:PM:INTern:SHAPE?                 (10)
```

The line (9) allows you to change the shape of the internal modulation signal. The parameters are : SIN for a sine signal, SQU for square.

The line (10) asks the current shape to the instrument. It sends back the same strings as the corresponding command parameters above.

```
:PM:STATe 0 | OFF | 1 | ON        (11)
:PM:STATe?                        (12)
```

The line (11) allows you to turn the PM on or off. The parameters «1» or «ON» turn it on, and «0» or «OFF» turn the modulation off (if present). The line (12) asks the current PM state to the instrument. It sends back «0» (char zero) if no PM is in progress, «1» (char one) if PM is present.

```
:PM:MODE ANA | NUM                (13)
:PM:MODE?                         (14)
```

The line (13) allows you to switch the operating mode (depending on the input bandwidth expected) of the external modulation. The parameters ANA and NUM are the same as the options in the external FM menu (refer to the corresponding paragraph). The line (14) asks the current mode to the instrument. It sends back the same strings as the corresponding command parameters above.

```
:PM:EXTern:COUPling AC | DC      (15)
:PM:EXTern:COUPling?            (16)
```

The line (15) allows you to switch the external input modulation in AC or DC mode. The line (16) asks the current state to the instrument. It sends back the same strings as the corresponding command parameters above.

Example:

```
:PM:UNIT DEG; DEV 120; INT:FREQ 1E+3;
SHAP SIN; MODE NUM; STATE 1
```

Commands tree - SYSTEM

Syntax:

```
:SYSTem:ERRor?
```

This line allows you to ask the current error code. This code is the first recorded even if several errors occur successively. After sending the error number the instrument sets it to zero

(it also set it to zero at power on time). Refer to the table of the error codes hereafter.

General syntax note

As mentioned in some examples above, in each command line the first character «:» is optional. In case of successive commands corresponding to the same tree it is not necessary to repeat all the description of the commands.

Example:

```
FM:INT:FREQ 9E+3; SHAP SIN; DEV 150E+3;
MODE NUM; STAT ON
```

is the same as :

```
:FM:INT:FREQ 9E+3; :FM:INT:SHAP SIN;
:FM:DEV 150E+3; MODE NUM; STAT ON
```

In fact „:FM“ for the first command indicates we get into the FM tree (group) and the commands after, if they belong to the same group, may be shorter (without repeating all the tree description). At the opposite if the next command does not belong to the same tree it is necessary to specify the root.

Operation - Error codes and their meaning

Error codes and their meaning

00	No error
01	Direct Digital Synthesis error (Hardware)
02	Internal reference error (Hardware)
03	External reference error (Hardware)
04	PLL1 error (Hardware)
05	PLL2 error (Hardware)
08	Calibration error
09	Overload error (Hardware)
15	Level error (out of range)
16	(Carrier) frequency error (out of range)
21	AM modulation in progress (impossible to turn another modulation on)
22	PM modulation in progress (impossible to turn another modulation on)
23	FM modulation in progress (impossible to turn another modulation on)
25	AM depth error (out of range)
62	FM deviation error (must be in the range 2kHz-400kHz)
63	FM deviation error (must be in the range 1kHz-200kHz)
64	FM deviation error (must be in the range 200Hz-150kHz)
70	AM frequency modulation error (must be in the range 10Hz-20kHz)
71	AM frequency modulation error (must be in the range 10Hz-40kHz)
75	PM deviation error (in remote control, no phase < 0)
76	frequency error (in remote control, no frequency < 0)
81	FM or PM frequency modulation error (must be in the range 10Hz-20kHz)
82	FM or PM frequency modulation error (must be in the range 10Hz-100kHz)
90	PM deviation error (must be in the range 0rad->3.14rad)
91	PM deviation error (must be in the range 0rad- 10.00rad)
92	PM deviation error (must be in the range 0deg- 180.0deg)
93	PM deviation error (must be in the range 0deg- 573.0deg)
-102	Syntax or Parameter error (remote control)
-103	Invalid Separator (remote control)
-110	Command header error (remote control)
-120	Numeric data error (remote control)

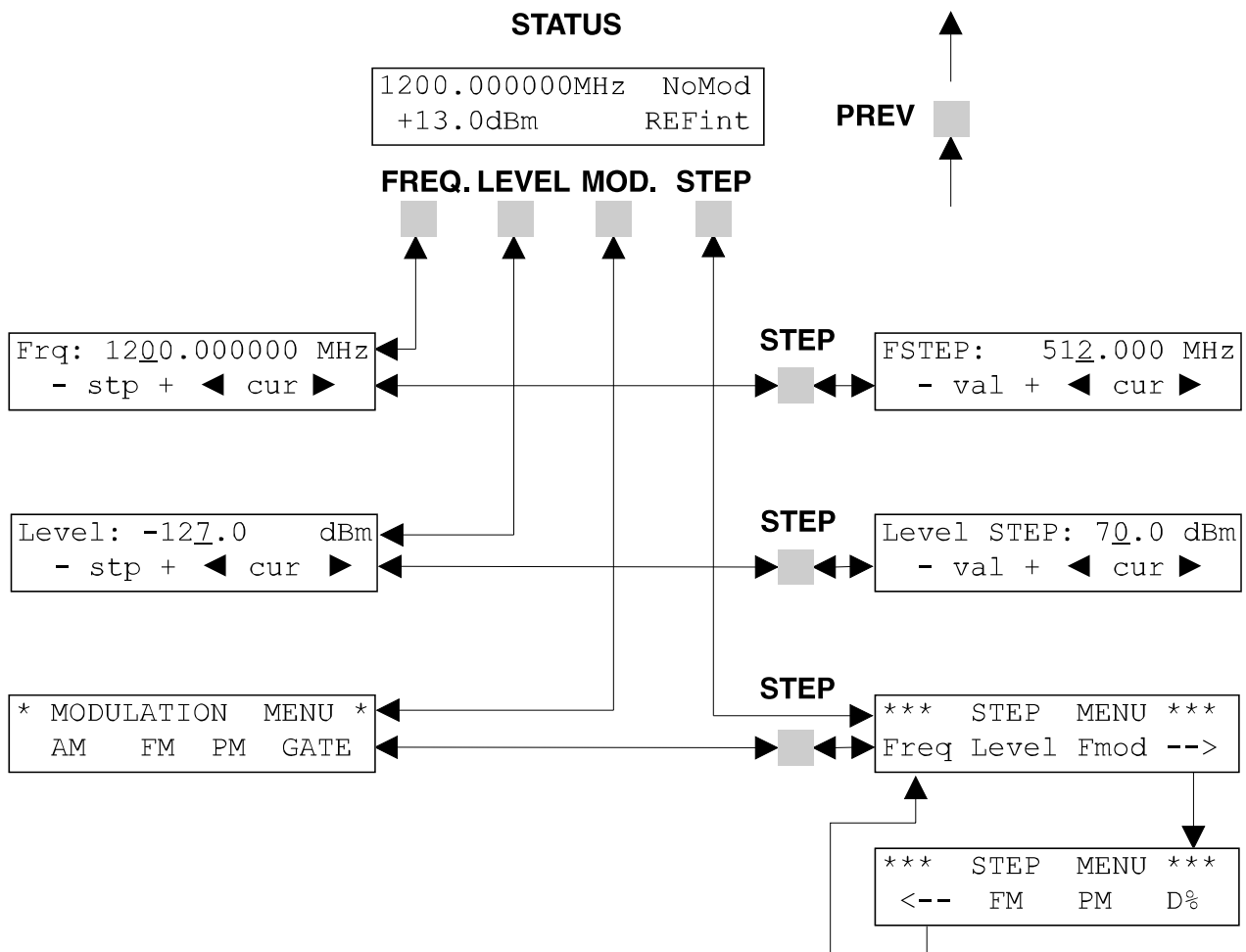

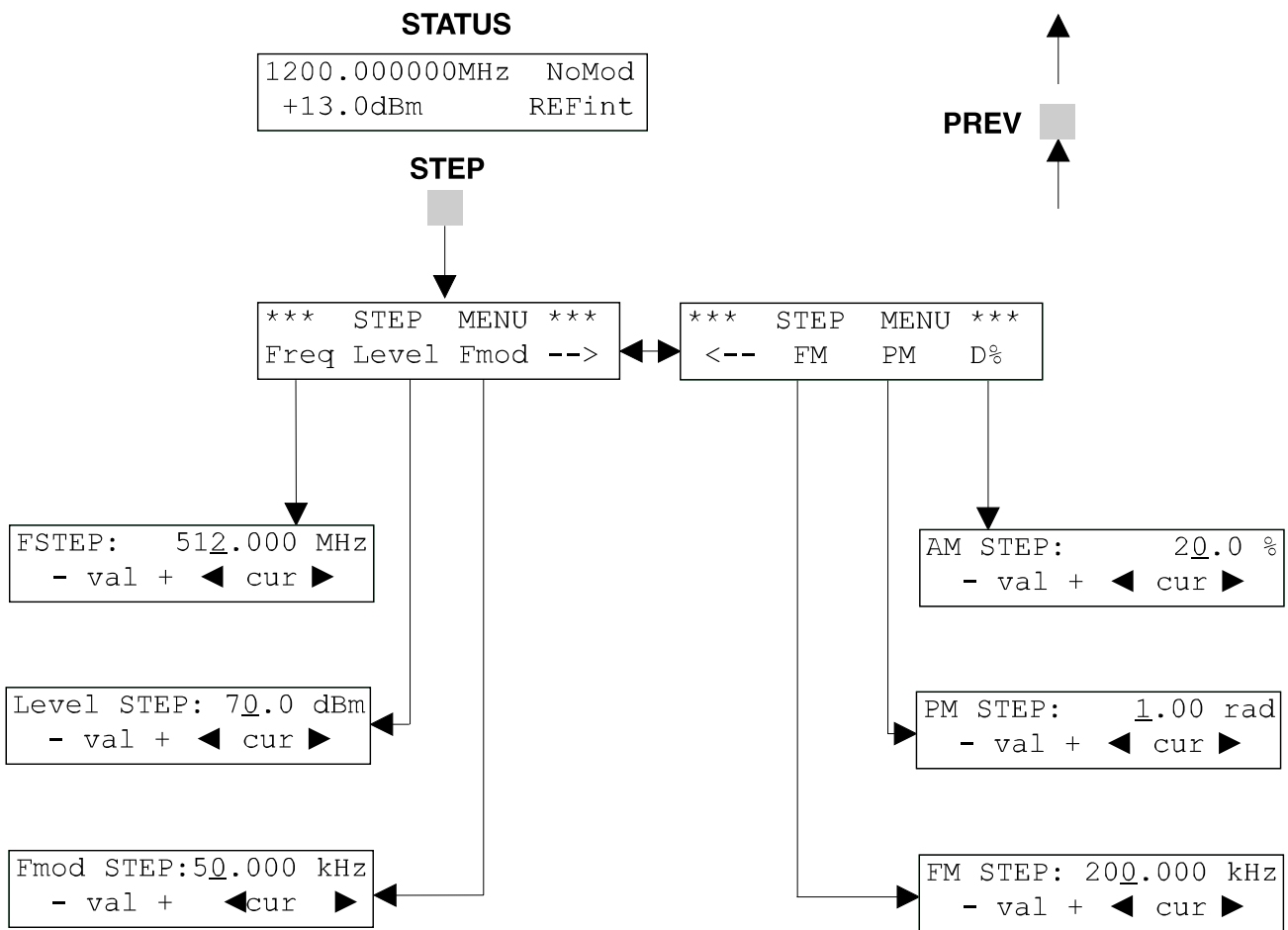

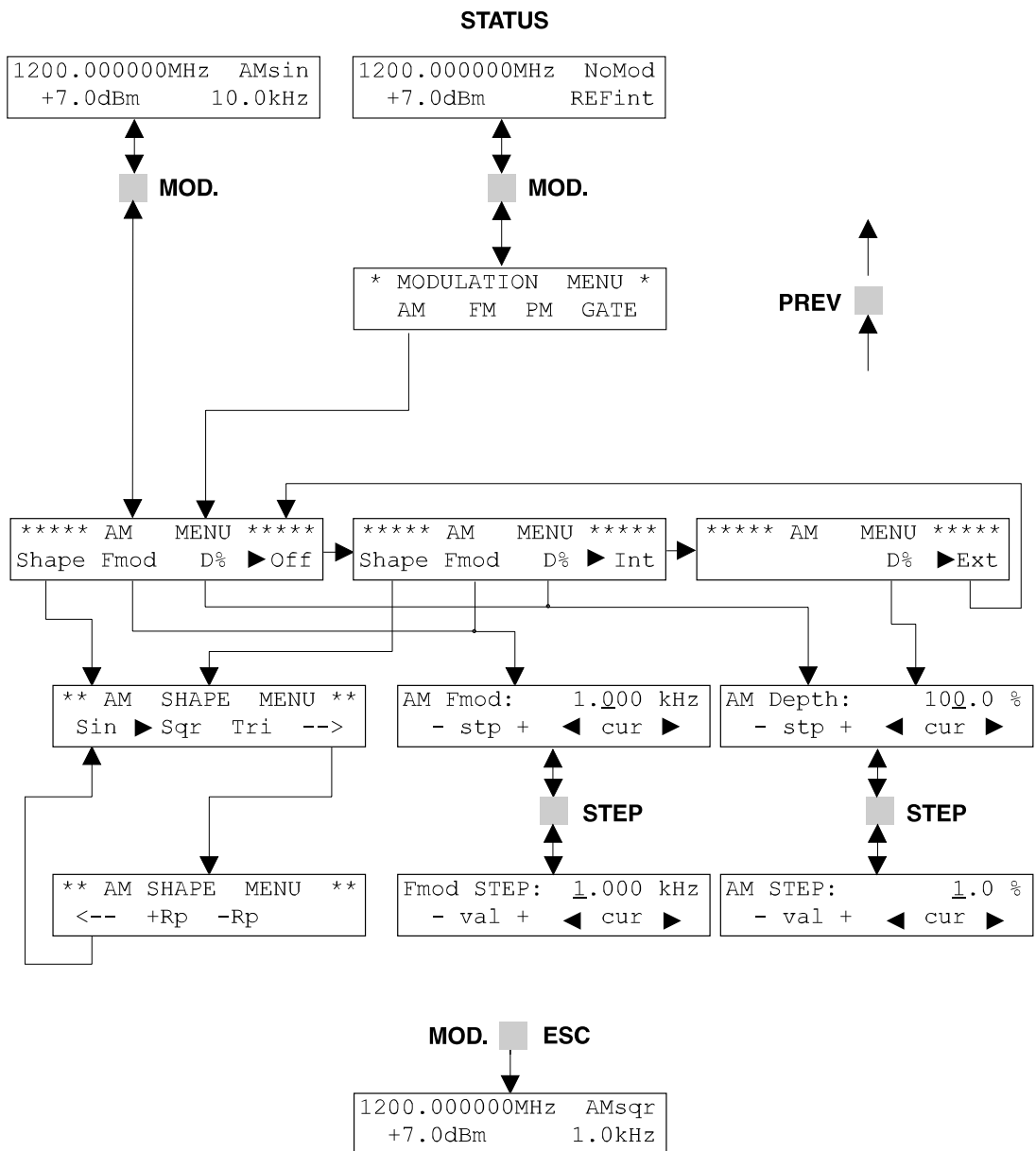

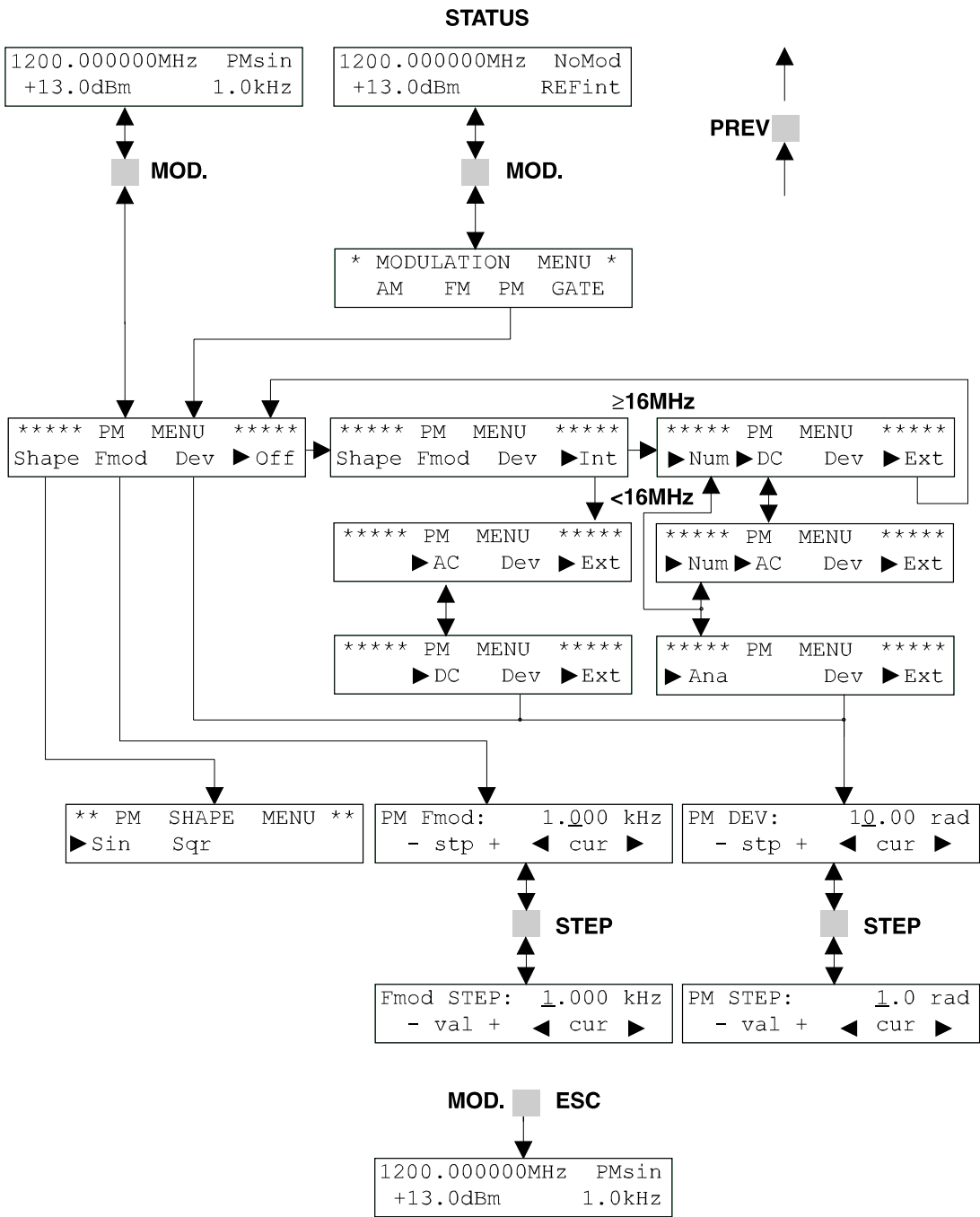

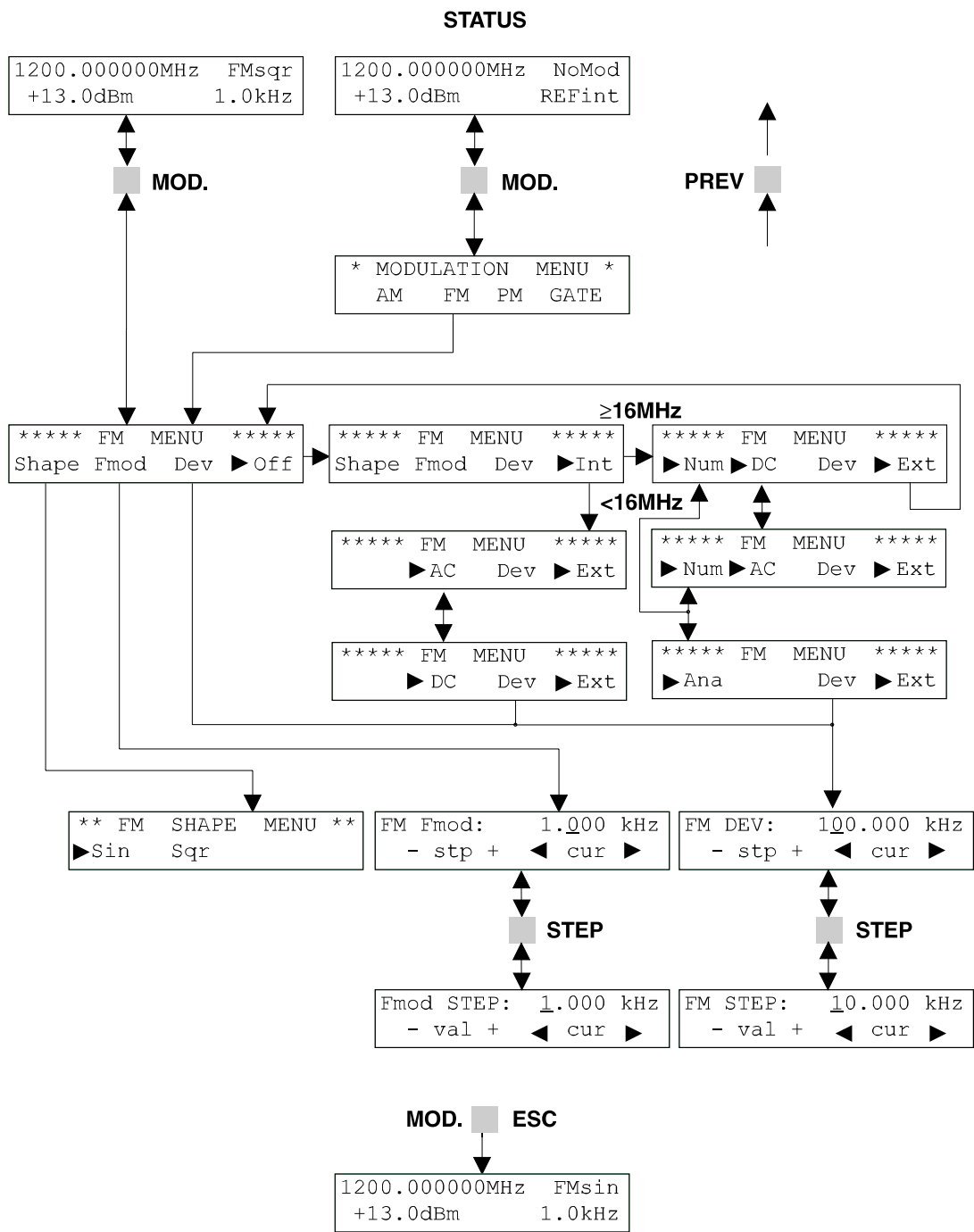

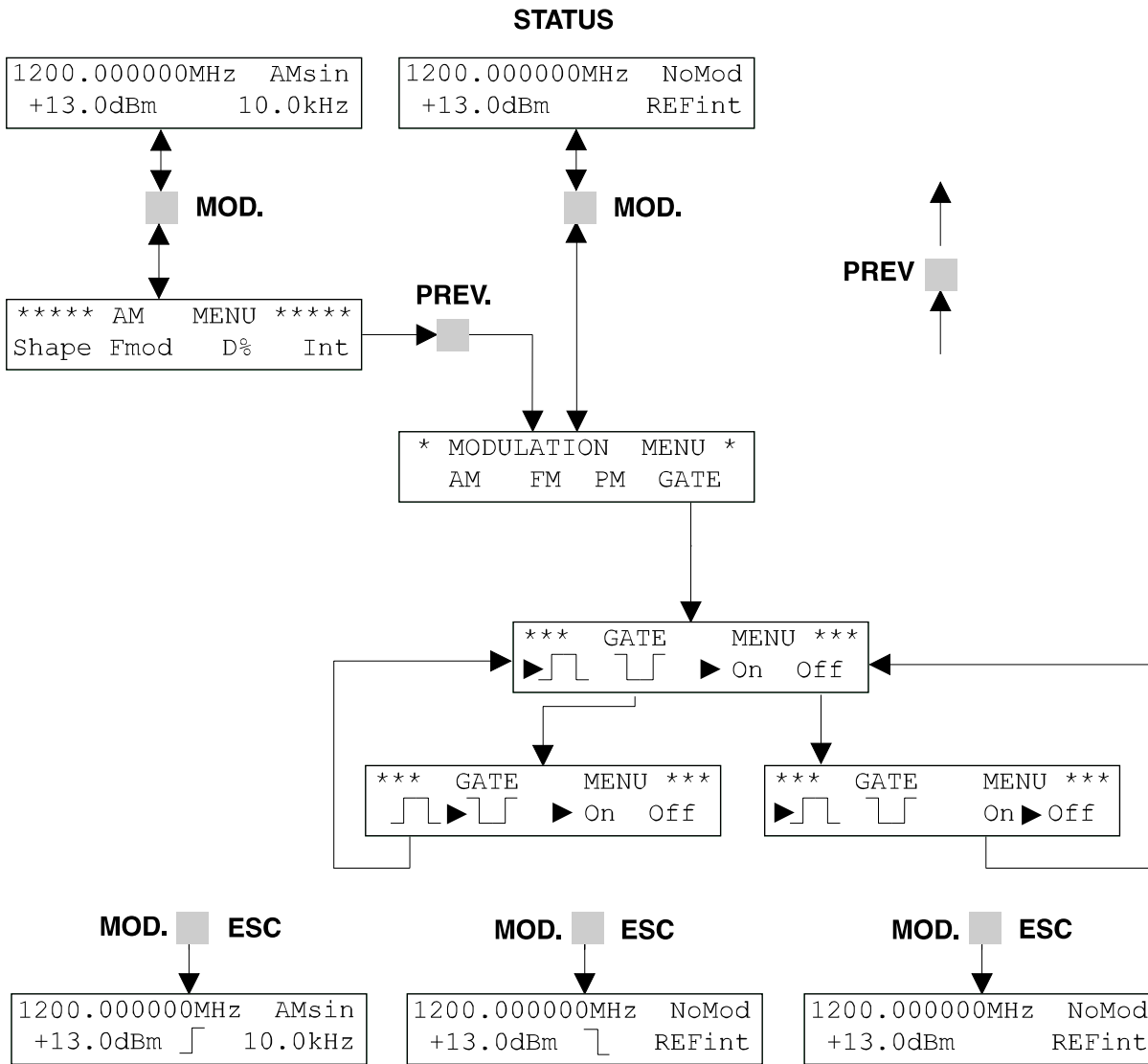

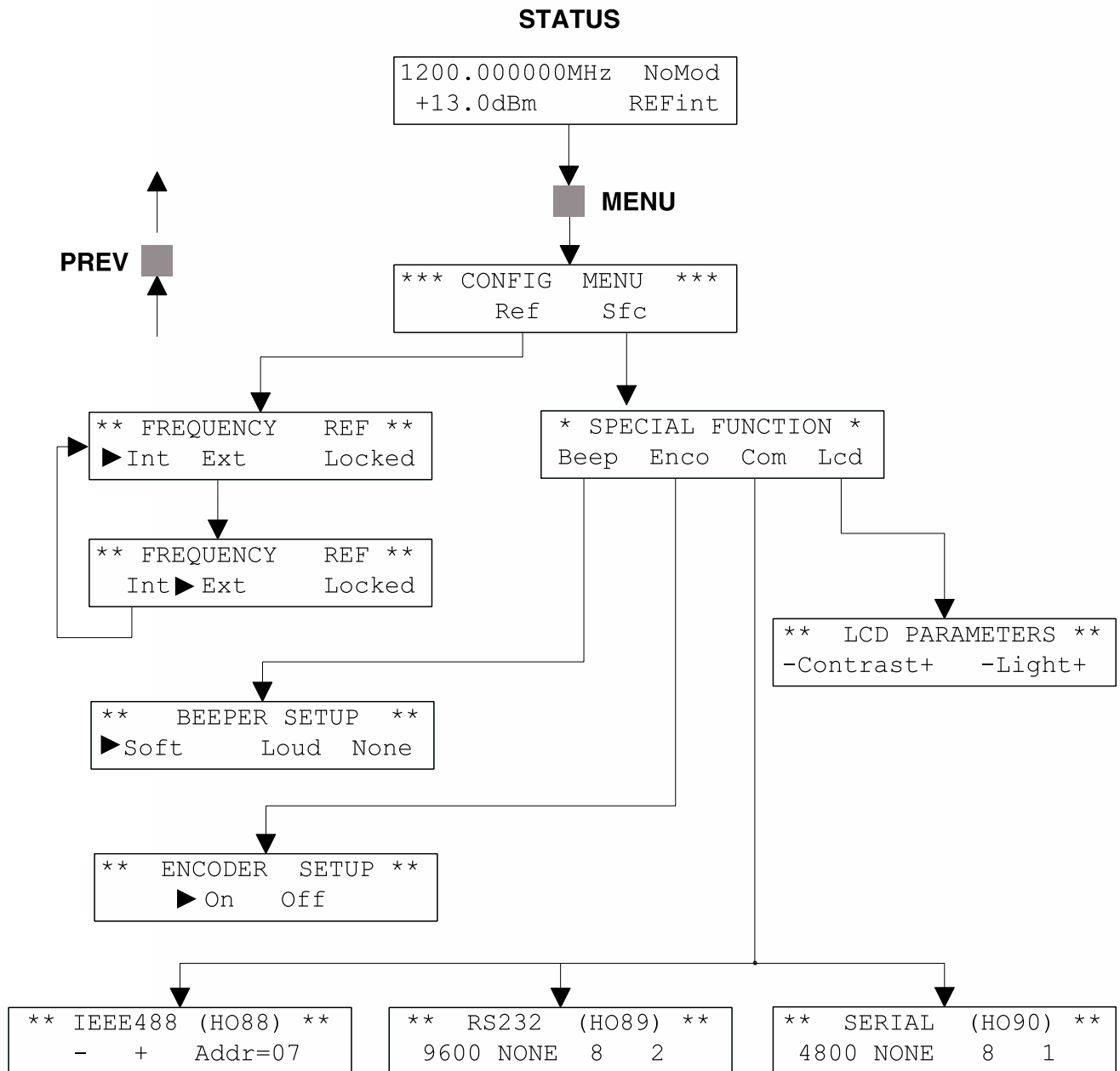

Referency loop CREF

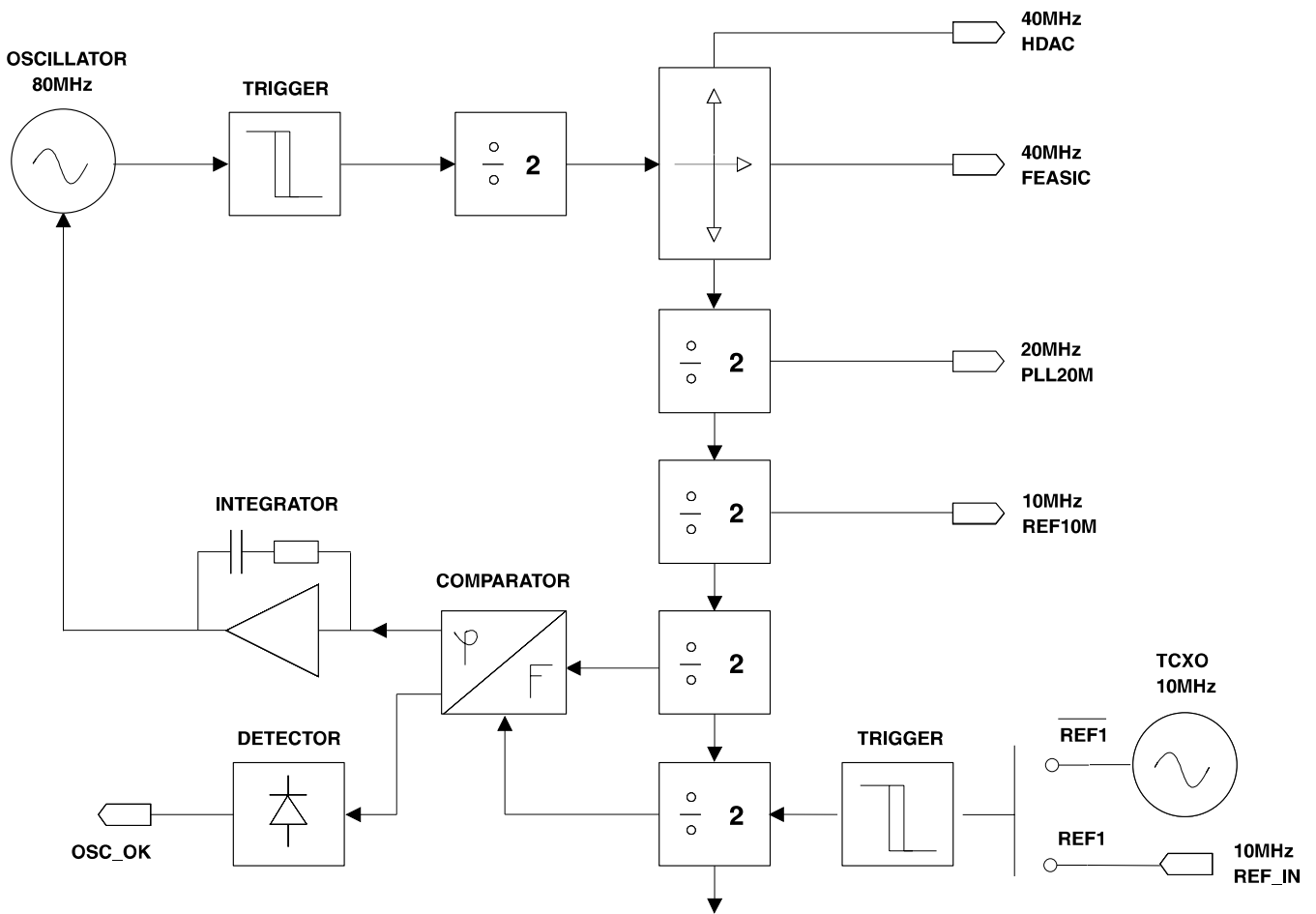

Principal loop PLL1-134

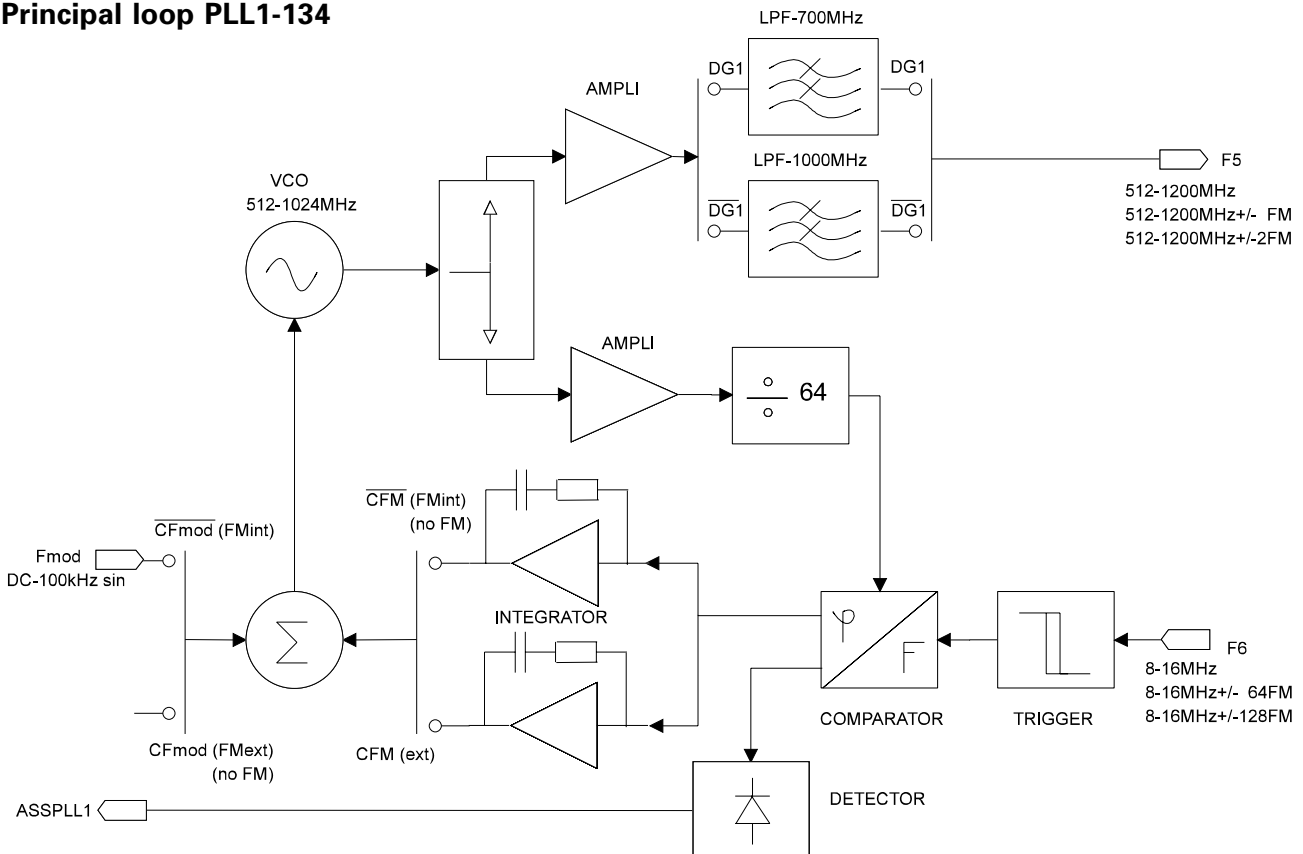

Secondary loop PLL2-134

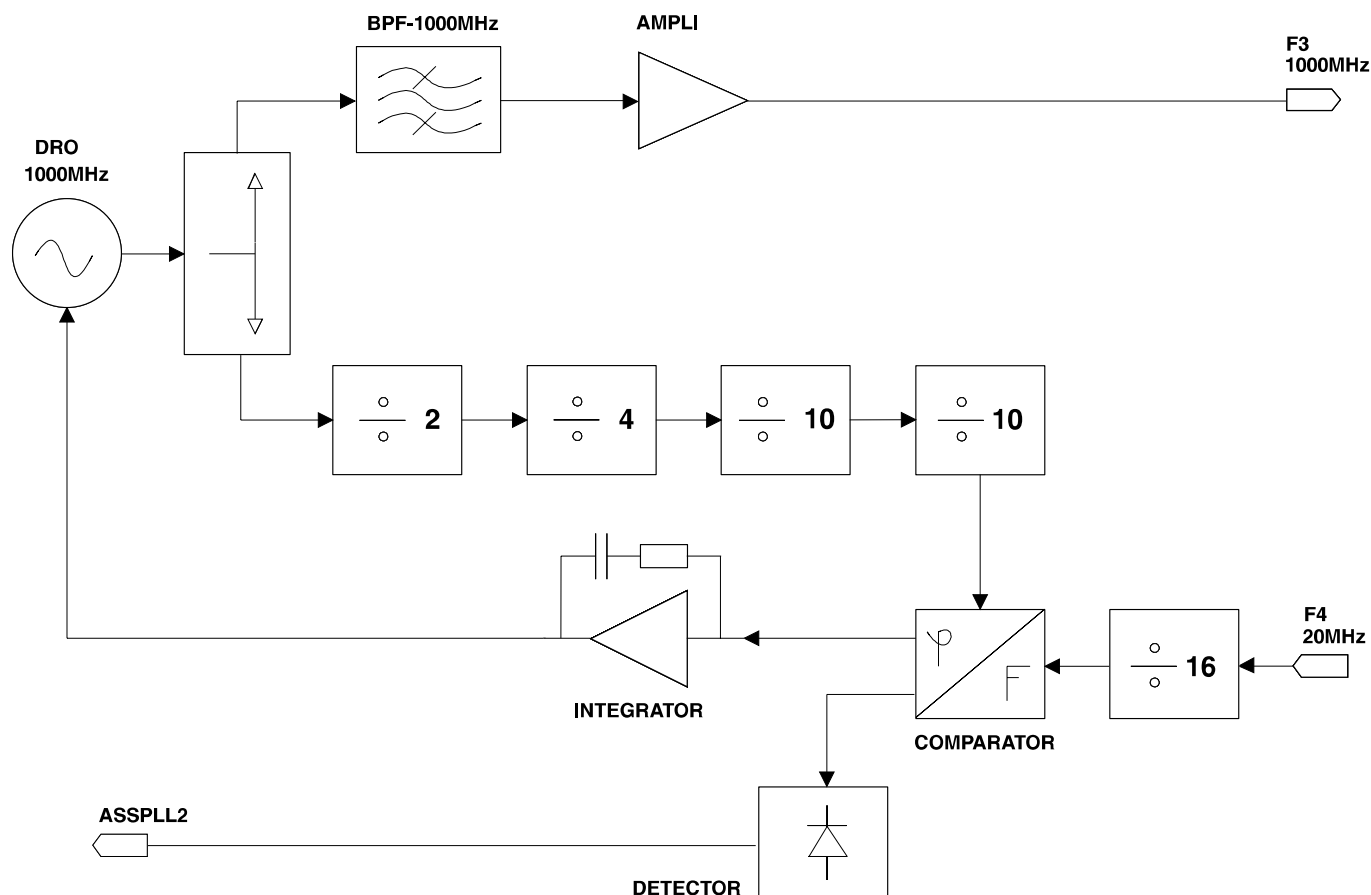

Transposition TRA-134

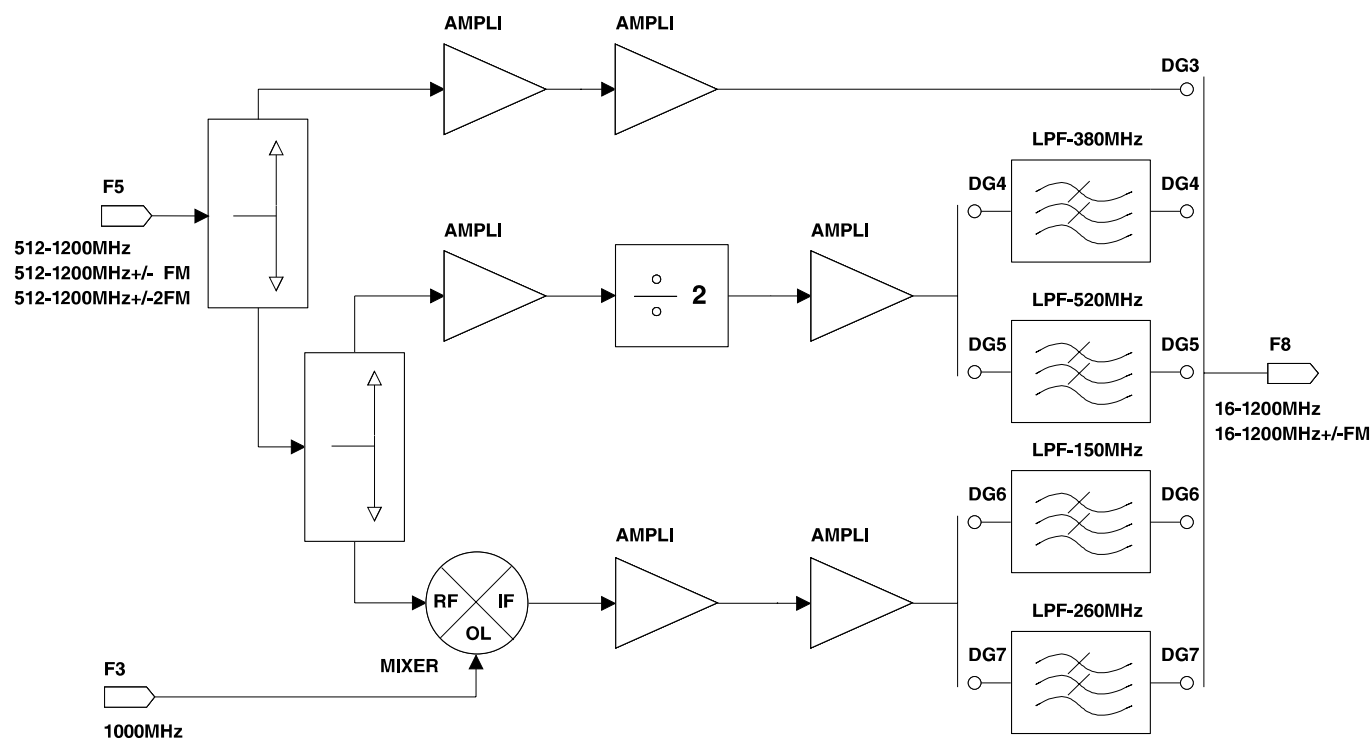

Frequency synthesise DDS134

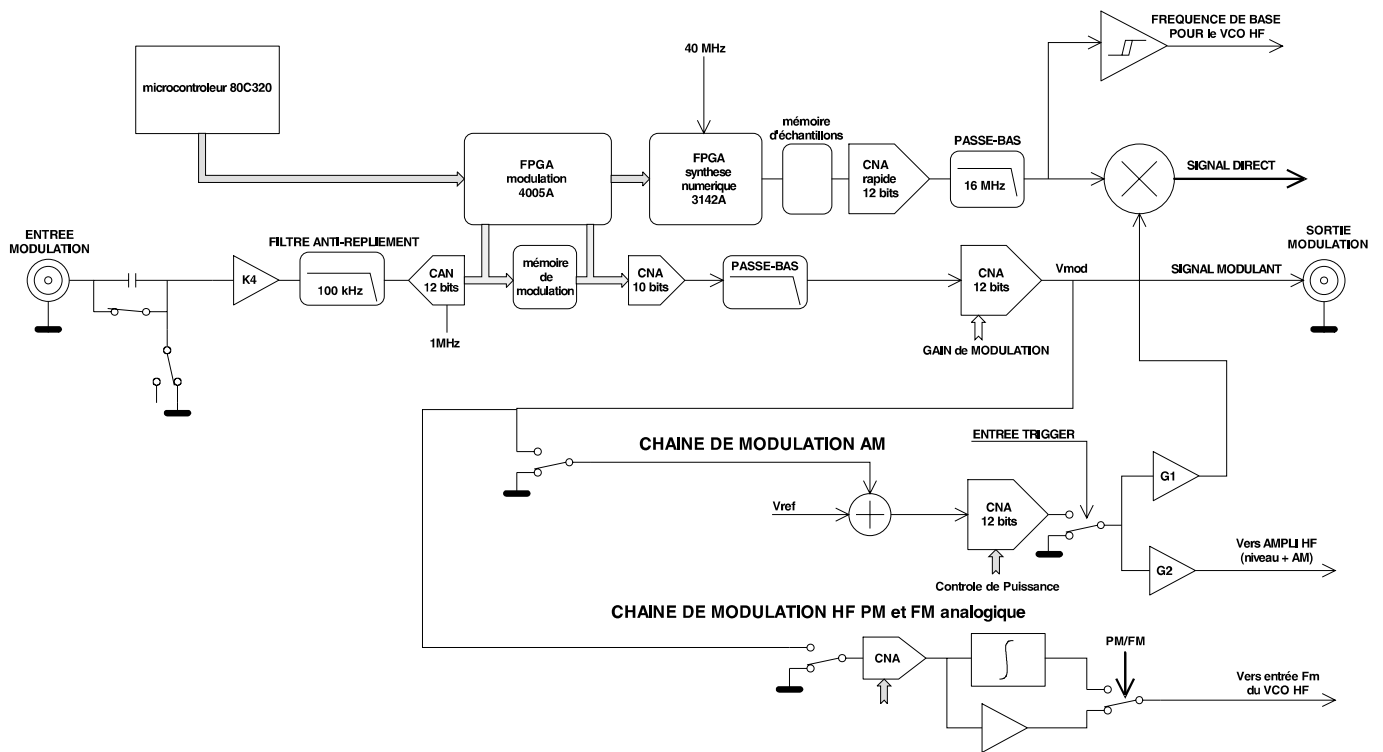

Level lock loop AMPL134

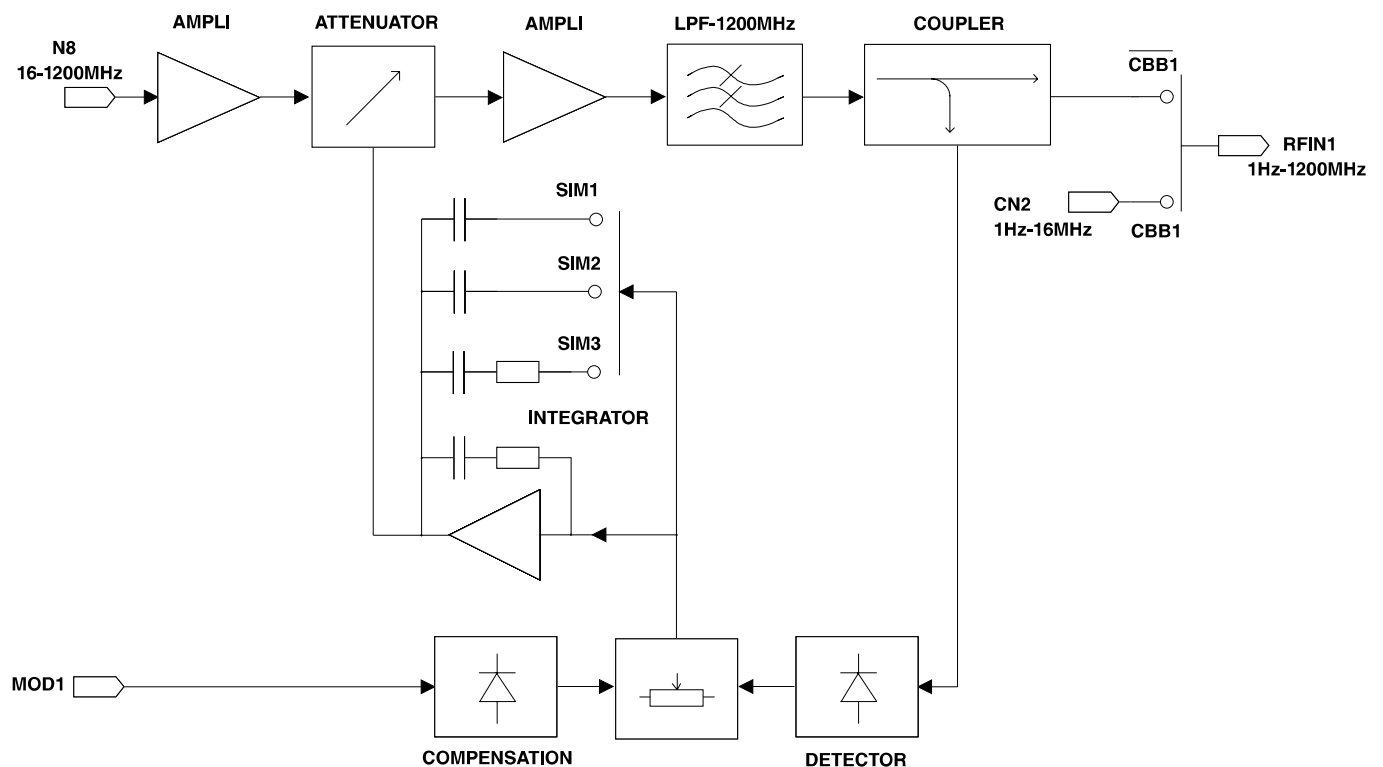

Programmable attenuator ATP134

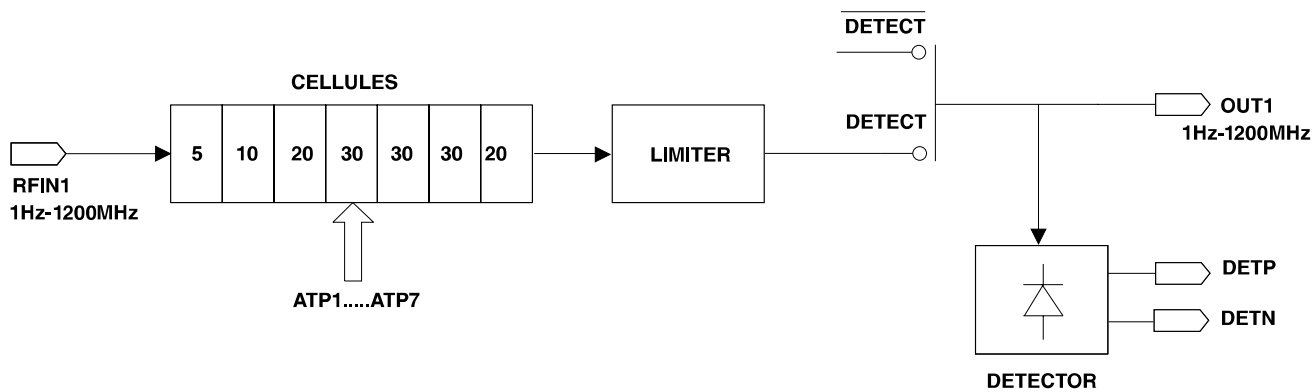

Conversion $\rho \leftrightarrow$ V.S.W.R.

REFLECTED FACTOR

$$\rho = \frac{Z - Z_0}{Z + Z_0}$$

STATIONARY WAVE RATIO

$$VSWR = \frac{1 + |\rho|}{1 - |\rho|}$$

$ \rho $	VSWR	$ \rho $	VSWR	$ \rho $	VSWR	$ \rho $	VSWR
0.00	1.00	0.25	1.67	0.50	3.00	0.75	7.00
0.01	1.02	0.26	1.70	0.51	3.08	0.76	7.33
0.02	1.04	0.27	1.74	0.52	3.17	0.77	7.70
0.03	1.06	0.28	1.78	0.53	3.26	0.78	8.09
0.04	1.08	0.29	1.82	0.54	3.35	0.79	8.52
0.05	1.11	0.30	1.86	0.55	3.44	0.80	9.00
0.06	1.13	0.31	1.90	0.56	3.55	0.81	9.53
0.07	1.15	0.32	1.94	0.57	3.65	0.82	10.11
0.08	1.17	0.33	1.99	0.58	3.76	0.83	10.76
0.09	1.20	0.34	2.03	0.59	3.88	0.84	11.50
0.10	1.22	0.35	2.08	0.60	4.00	0.85	12.33
0.11	1.25	0.36	2.13	0.61	4.13	0.86	13.29
0.12	1.27	0.37	2.17	0.62	4.26	0.87	14.38
0.13	1.30	0.38	2.23	0.63	4.41	0.88	15.67
0.14	1.33	0.39	2.28	0.64	4.56	0.89	17.18
0.15	1.35	0.40	2.33	0.65	4.71	0.90	19.00
0.16	1.38	0.41	2.39	0.66	4.88	0.91	21.22
0.17	1.41	0.42	2.45	0.67	5.06	0.92	24.00
0.18	1.44	0.43	2.51	0.68	5.25	0.93	27.57
0.19	1.47	0.44	2.57	0.69	5.45	0.94	32.33
0.20	1.50	0.45	2.64	0.70	5.67	0.95	39.00
0.21	1.53	0.46	2.70	0.71	5.90	0.96	49.00
0.22	1.56	0.47	2.77	0.72	6.14	0.97	65.67
0.23	1.60	0.48	2.85	0.73	6.41	0.98	99.00
0.24	1.63	0.49	2.92	0.74	6.69	0.99	199.00

Conversion dBm ↔ Volt

CONVERSION dBm → Volt

$$V_0 = \sqrt{R \cdot P_0} \cdot 10^{\frac{P_{dBm}}{20}}$$

CONVERSION Volt → dBm

$$P_{dBm} = 20 \cdot \log \frac{V_0}{\sqrt{R \cdot P_0}}$$

with: $P_0 = 1mW$ and $R = 50\Omega$

dBm	Volt	dBm	Volt	dBm	Volt	dBm	Volt	dBm	Volt
+20.0	2.236	+16.0	1.411	+12.0	0.890	+8.0	0.562	+4.0	0.354
+19.9	2.210	+15.9	1.395	+11.9	0.880	+7.9	0.555	+3.9	0.350
+19.8	2.185	+15.8	1.379	+11.8	0.870	+7.8	0.549	+3.8	0.346
+19.7	2.160	+15.7	1.363	+11.7	0.860	+7.7	0.543	+3.7	0.342
+19.6	2.135	+15.6	1.347	+11.6	0.850	+7.6	0.536	+3.6	0.338
+19.5	2.111	+15.5	1.332	+11.5	0.840	+7.5	0.530	+3.5	0.335
+19.4	2.087	+15.4	1.317	+11.4	0.831	+7.4	0.524	+3.4	0.331
+19.3	2.063	+15.3	1.302	+11.3	0.821	+7.3	0.518	+3.3	0.327
+19.2	2.039	+15.2	1.287	+11.2	0.812	+7.2	0.512	+3.2	0.323
+19.1	2.016	+15.1	1.272	+11.1	0.803	+7.1	0.506	+3.1	0.320
+19.0	1.993	+15.0	1.257	+11.0	0.793	+7.0	0.501	+3.0	0.316
+18.9	1.970	+14.9	1.243	+10.9	0.784	+6.9	0.495	+2.9	0.312
+18.8	1.948	+14.8	1.229	+10.8	0.775	+6.8	0.489	+2.8	0.309
+18.7	1.925	+14.7	1.215	+10.7	0.766	+6.7	0.484	+2.7	0.305
+18.6	1.903	+14.6	1.201	+10.6	0.758	+6.6	0.478	+2.6	0.302
+18.5	1.881	+14.5	1.187	+10.5	0.749	+6.5	0.473	+2.5	0.298
+18.4	1.860	+14.4	1.174	+10.4	0.740	+6.4	0.467	+2.4	0.295
+18.3	1.839	+14.3	1.160	+10.3	0.732	+6.3	0.462	+2.3	0.291
+18.2	1.818	+14.2	1.147	+10.2	0.724	+6.2	0.457	+2.2	0.288
+18.1	1.797	+14.1	1.134	+10.1	0.715	+6.1	0.451	+2.1	0.285
+18.0	1.776	+14.0	1.121	+10.0	0.707	+6.0	0.446	+2.0	0.282
+17.9	1.756	+13.9	1.108	+9.9	0.699	+5.9	0.441	+1.9	0.278
+17.8	1.736	+13.8	1.095	+9.8	0.691	+5.8	0.436	+1.8	0.275
+17.7	1.716	+13.7	1.083	+9.7	0.683	+5.7	0.431	+1.7	0.272
+17.6	1.696	+13.6	1.070	+9.6	0.675	+5.6	0.426	+1.6	0.269
+17.5	1.677	+13.5	1.058	+9.5	0.668	+5.5	0.421	+1.5	0.266
+17.4	1.658	+13.4	1.046	+9.4	0.660	+5.4	0.416	+1.4	0.263
+17.3	1.639	+13.3	1.034	+9.3	0.652	+5.3	0.412	+1.3	0.260
+17.2	1.620	+13.2	1.022	+9.2	0.645	+5.2	0.407	+1.2	0.257
+17.1	1.601	+13.1	1.010	+9.1	0.638	+5.1	0.402	+1.1	0.254
+17.0	1.583	+13.0	0.999	+9.0	0.630	+5.0	0.398	+1.0	0.251
+16.9	1.565	+12.9	0.987	+8.9	0.623	+4.9	0.393	+0.9	0.248
+16.8	1.547	+12.8	0.976	+8.8	0.616	+4.8	0.389	+0.8	0.245
+16.7	1.529	+12.7	0.965	+8.7	0.609	+4.7	0.384	+0.7	0.242
+16.6	1.512	+12.6	0.954	+8.6	0.602	+4.6	0.380	+0.6	0.240
+16.5	1.494	+12.5	0.943	+8.5	0.595	+4.5	0.375	+0.5	0.237
+16.4	1.477	+12.4	0.932	+8.4	0.588	+4.4	0.371	+0.4	0.234
+16.3	1.460	+12.3	0.921	+8.3	0.581	+4.3	0.367	+0.3	0.231
+16.2	1.444	+12.2	0.911	+8.2	0.575	+4.2	0.363	+0.2	0.229
+16.1	1.427	+12.1	0.901	+8.1	0.568	+4.1	0.358	+0.1	0.226

Conversion dBm ↔ mW

CONVERSION mW → dBm

$$P_{dBm} = 10 \cdot \log \frac{P_{mW}}{P_0}$$

CONVERSION dBm → mW

$$P_{mW} = P_0 \cdot 10^{\frac{P_{dBm}}{10}}$$

with: $P_0 = 1mW$

dBm	mW	dBm	mW	dBm	mW	dBm	mW	dBm	mW
+20.0	100.000	+16.0	39.811	+12.0	15.849	+8.0	6.310	+4.0	2.512
+19.9	97.724	+15.9	38.905	+11.9	15.488	+7.9	6.166	+3.9	2.455
+19.8	95.499	+15.8	38.019	+11.8	15.136	+7.8	6.026	+3.8	23.99
+19.7	93.325	+15.7	37.154	+11.7	14.791	+7.7	5.888	+3.7	2.344
+19.6	91.201	+15.6	36.308	+11.6	14.454	+7.6	5.754	+3.6	2.291
+19.5	89.125	+15.5	35.481	+11.5	14.125	+7.5	5.623	+3.5	2.239
+19.4	87.096	+15.4	34.674	+11.4	13.804	+7.4	5.495	+3.4	2.188
+19.3	85.114	+15.3	33.884	+11.3	13.490	+7.3	5.370	+3.3	2.138
+19.2	83.176	+15.2	33.113	+11.2	13.183	+7.2	5.248	+3.2	2.089
+19.1	81.283	+15.1	32.359	+11.1	12.882	+7.1	5.129	+3.1	2.042
+19.0	79.433	+15.0	31.623	+11.0	12.589	+7.0	5.012	+3.0	1.995
+18.9	77.625	+14.9	30.903	+10.9	12.303	+6.9	4.898	+2.9	1.950
+18.8	75.858	+14.8	30.200	+10.8	12.023	+6.8	4.786	+2.8	1.905
+18.7	74.131	+14.7	29.512	+10.7	11.749	+6.7	4.677	+2.7	1.862
+18.6	72.444	+14.6	28.840	+10.6	11.482	+6.6	4.571	+2.6	1.820
+18.5	70.795	+14.5	28.184	+10.5	11.220	+6.5	4.467	+2.5	1.778
+18.4	69.183	+14.4	27.542	+10.4	10.965	+6.4	4.365	+2.4	1.738
+18.3	67.608	+14.3	26.915	+10.3	10.715	+6.3	4.266	+2.3	1.698
+18.2	66.069	+14.2	26.303	+10.2	10.471	+6.2	4.169	+2.2	1.660
+18.1	64.565	+14.1	25.704	+10.1	10.233	+6.1	4.074	+2.1	1.622
+18.0	63.096	+14.0	25.119	+10.0	10.000	+6.0	3.981	+2.0	1.585
+17.9	61.660	+13.9	24.547	+9.9	9.772	+5.9	3.890	+1.9	1.549
+17.8	60.256	+13.8	23.988	+9.8	9.550	+5.8	3.802	+1.8	1.514
+17.7	58.884	+13.7	23.442	+9.7	9.333	+5.7	3.715	+1.7	1.479
+17.6	57.544	+13.6	22.909	+9.6	9.120	+5.6	3.631	+1.6	1.445
+17.5	56.234	+13.5	22.387	+9.5	8.913	+5.5	3.548	+1.5	1.413
+17.4	54.954	+13.4	21.878	+9.4	8.710	+5.4	3.467	+1.4	1.380
+17.3	53.703	+13.3	21.380	+9.3	8.511	+5.3	3.388	+1.3	1.349
+17.2	52.481	+13.2	20.893	+9.2	8.318	+5.2	3.311	+1.2	1.318
+17.1	51.286	+13.1	20.417	+9.1	8.128	+5.1	3.236	+1.1	1.288
+17.0	50.119	+13.0	19.953	+9.0	7.943	+5.0	3.162	+1.0	1.259
+16.9	48.978	+12.9	19.498	+8.9	7.762	+4.9	3.090	+0.9	1.230
+16.8	47.863	+12.8	19.055	+8.8	7.586	+4.8	3.020	+0.8	1.202
+16.7	46.774	+12.7	18.621	+8.7	7.413	+4.7	2.951	+0.7	1.175
+16.6	45.709	+12.6	18.197	+8.6	7.244	+4.6	2.884	+0.6	1.148
+16.5	44.668	+12.5	17.783	+8.5	7.079	+4.5	2.818	+0.5	1.122
+16.4	43.652	+12.4	17.378	+8.4	6.918	+4.4	2.754	+0.4	1.096
+16.3	42.658	+12.3	16.982	+8.3	6.761	+4.3	2.692	+0.3	1.072
+16.2	41.687	+12.2	16.596	+8.2	6.607	+4.2	2.630	+0.2	1.047
+16.1	40.738	+12.1	16.218	+8.1	6.457	+4.1	2.570	+0.1	1.023

Conversion dBm ↔ Ratio

CONVERSION Ratio → dBm

$$P_{dBm} = 20 \cdot \log \frac{U_S}{U_E}$$

CONVERSION dBm → Ratio

$$\frac{U_S}{U_E} = 10^{\frac{P_{dBm}}{20}}$$

dBm	Ratio	dBm	Ratio	dBm	Ratio	dBm	Ratio	dBm	Ratio
0.0	1.000	4.6	1.698	9.2	2.884	13.8	4.898	18.4	8.318
0.1	1.012	4.7	1.718	9.3	2.917	13.9	4.955	18.5	8.414
0.2	1.023	4.8	1.738	9.4	2.951	14.0	5.012	18.6	8.511
0.3	1.035	4.9	1.758	9.5	2.985	14.1	5.070	18.7	8.610
0.4	1.047	5.0	1.778	9.6	3.020	14.2	5.129	18.8	8.710
0.5	1.059	5.1	1.799	9.7	3.055	14.3	5.188	18.9	8.810
0.6	1.072	5.2	1.820	9.8	3.090	14.4	5.248	19.0	8.913
0.7	1.084	5.3	1.841	9.9	3.126	14.5	5.309	19.1	9.016
0.8	1.096	5.4	1.862	10.0	3.162	14.6	5.370	19.2	9.120
0.9	1.109	5.5	1.884	10.1	3.199	14.7	5.433	19.3	9.226
1.0	1.122	5.6	1.905	10.2	3.236	14.8	5.495	19.4	9.333
1.1	1.135	5.7	1.928	10.3	3.273	14.9	5.559	19.5	9.441
1.2	1.148	5.8	1.950	10.4	3.311	15.0	5.623	19.6	9.550
1.3	1.161	5.9	1.972	10.5	3.350	15.1	5.689	19.7	9.661
1.4	1.175	6.0	1.995	10.6	3.388	15.2	5.754	19.8	9.772
1.5	1.189	6.1	2.018	10.7	3.428	15.3	5.821	19.9	9.886
1.6	1.202	6.2	2.042	10.8	3.467	15.4	5.888	20	10.000
1.7	1.216	6.3	2.065	10.9	3.508	15.5	5.957	20.1	10.116
1.8	1.230	6.4	2.089	11.0	3.548	15.6	6.026	20.2	10.233
1.9	1.245	6.5	2.113	11.1	3.589	15.7	6.095	20.3	10.351
2.0	1.259	6.6	2.138	11.2	3.631	15.8	6.166	20.4	10.471
2.1	1.274	6.7	2.163	11.3	3.673	15.9	6.237	20.5	10.593
2.2	1.288	6.8	2.188	11.4	3.715	16.0	6.310	20.6	10.715
2.3	1.303	6.9	2.213	11.5	3.758	16.1	6.383	20.7	10.839
2.4	1.318	7.0	2.239	11.6	3.802	16.2	6.457	20.8	10.965
2.5	1.334	7.1	2.265	11.7	3.846	16.3	6.531	20.9	11.092
2.6	1.349	7.2	2.291	11.8	3.890	16.4	6.607	21	11.220
2.7	1.365	7.3	2.317	11.9	3.936	16.5	6.683	21.1	11.350
2.8	1.380	7.4	2.344	12.0	3.981	16.6	6.761	21.2	11.482
2.9	1.396	7.5	2.371	12.1	4.027	16.7	6.839	21.3	11.614
3.0	1.413	7.6	2.399	12.2	4.074	16.8	6.918	21.4	11.749
3.1	1.429	7.7	2.427	12.3	4.121	16.9	6.998	21.5	11.885
3.2	1.445	7.8	2.455	12.4	4.169	17.0	7.079	21.6	12.023
3.3	1.462	7.9	2.483	12.5	4.217	17.1	7.161	21.7	12.162
3.4	1.479	8.0	2.512	12.6	4.266	17.2	7.244	21.8	12.303
3.5	1.496	8.1	2.541	12.7	4.315	17.3	7.328	21.9	12.445
3.6	1.514	8.2	2.570	12.8	4.365	17.4	7.413	22	12.589
3.7	1.531	8.3	2.600	12.9	4.416	17.5	7.499	22.1	12.735
3.8	1.549	8.4	2.630	13.0	4.467	17.6	7.586	22.2	12.882
3.9	1.567	8.5	2.661	13.1	4.519	17.7	7.674	22.3	13.032
4.0	1.585	8.6	2.692	13.2	4.571	17.8	7.762	22.4	13.183
4.1	1.603	8.7	2.723	13.3	4.624	17.9	7.852	22.5	13.335
4.2	1.622	8.8	2.754	13.4	4.677	18.0	7.943	22.6	13.490
4.3	1.641	8.9	2.786	13.5	4.732	18.1	8.035	22.7	13.646
4.4	1.660	9.0	2.818	13.6	4.786	18.2	8.128	22.8	13.804
4.5	1.679	9.1	2.851	13.7	4.842	18.3	8.222	22.9	13.964

Conversion dB μ V \leftrightarrow Volt

CONVERSION Volt \rightarrow dB μ V

CONVERSION dB μ V \rightarrow Volt

$$P_{dB\mu V} = 20 \cdot \log \frac{U}{U_0}$$

$$U = U_0 \cdot 10^{\frac{P_{dB\mu V}}{20}}$$

with: $U_0 = 1\mu V$

dB μ V	μ Volt	dB μ V	μ Volt	dB μ V	mVolt	dB μ V	mVolt	dB μ V	Volt
0	1.00	40	100	60	1.00	100	100	120	1.00
1	1.12	41	112	61	1.12	101	112	121	1.12
2	1.26	42	126	62	1.26	102	126	122	1.26
3	1.41	43	141	63	1.41	103	141	123	1.41
4	1.58	44	158	64	1.58	104	158	124	1.58
5	1.78	45	178	65	1.78	105	178	125	1.78
6	2.00	46	200	66	2.00	106	200	126	2.00
7	2.24	47	224	67	2.24	107	224	127	2.24
8	2.51	48	251	68	2.51	108	251	128	2.51
9	2.82	49	282	69	2.82	109	282	129	2.82
10	3.16	50	316	70	3.16	110	316		
11	3.55	51	355	71	3.55	111	355		
12	3.98	52	398	72	3.98	112	398		
13	4.47	53	447	73	4.47	113	447		
14	5.01	54	501	74	5.01	114	501		
15	5.62	55	562	75	5.62	115	562		
16	6.31	56	631	76	6.31	116	631		
17	7.08	57	708	77	7.08	117	708		
18	7.94	58	794	78	7.94	118	794		
19	8.91	59	891	79	8.91	119	891		
20	10.0			80	10.0				
21	11.2			81	11.2				
22	12.6			82	12.6				
23	14.1			83	14.1				
24	15.8			84	15.8				
25	17.8			85	17.8				
26	20.0			86	20.0				
27	22.4			87	22.4				
28	25.1			88	25.1				
29	28.2			89	28.2				
30	31.6			90	31.6				
31	35.5			91	35.5				
32	39.8			92	39.8				
33	44.7			93	44.7				
34	50.1			94	50.1				
35	56.2			95	56.2				
36	63.1			96	63.1				
37	70.8			97	70.8				
38	79.4			98	79.4				
39	89.1			99	89.1				
40	100								





HAMEG[®] **Instruments**

Oscilloscopes

Multimeters

Counters

Frequency Synthesizers

Generators

R- and LC-Meters

Spectrum Analyzers

Power Supplies

Curve Tracers

45-8134-02E0

HAMEG GmbH

Industriestraße 6

D-63533 Mainhausen

Telefon: +49 (0) 6182 / 800-0

Telefax: +49 (0) 6182 / 800-100

E-mail: sales@hameg.de

service@hameg.de

Internet:

www.hameg.de

Printed in Germany